

MODULE- I

Philosophy of Protection

The purpose of an Electric Power System is to generate and supply electrical energy to consumers. The power system should be designed and managed to deliver this energy to the utilization points with both reliability and economically

The capital investment involved in power system for the generation, transmission and distribution is so great that the proper precautions must be taken to ensure that the equipment not only operates as nearly as possible to peak efficiency, but also must be protected from accidents

The normal path of the electric current is from the power source through copper (or aluminium) conductors in generators, transformers and transmission lines to the load and it is confined to this path by insulation.

Nature of Faults

- Short circuit fault- current
- Open circuit fault- voltage

In terms of seriousness of consequences of a fault, short circuits are of far greater concern than open circuits, although some open circuits present some potential hazards to personnel

Classification of short circuited Faults

- Three phase faults (with or without earth connection)
- Two phase faults (with or without earth connection)
- Single phase to earth faults

Classification of Open Circuit Faults

- Single Phase open Circuit
- Two phase open circuit
- Three phase open circuit

Causes of Faults

The insulation, however, may break down, either by the effect of temperature and age or by a physical accident, so that the current then follows an abnormal path generally known as Short Circuit or Fault

- Any abnormal operating state of a power system is known as FAULT.

- A fault in general consists of short circuits as well as open circuits.
- Open circuit faults are less frequent than short circuit faults, and often they are transformed in to short circuits by subsequent event

Consequences of occurrence of Faults

- Expensive damage to the equipment due to abnormally large currents, unbalanced currents, or low voltages produced by the short circuits
- Explosions which may occur in equipment containing insulating oil during short circuits and which may cause fire resulting in serious hazard to personnel and to other equipment
- Sever drop in voltage which is likely to cause the individual generators in a power station or a group of generators in different stations to loose synchronism and fall out of step with consequent splitting of the system
- A risk of synchronous motors in large industrial premises falling out of step and tripping out.

Zones of Protection

- An electric power system is divided into zones of protection as shown in Fig. 1.1. Each zone of protection contains one or more components of a power system in addition to two circuit breakers.
- For a fault with in the boundary of a zone, the protection system responsible for the protection of the zone acts to isolate (by tripping CBs) everything with in that zone from the rest of the system

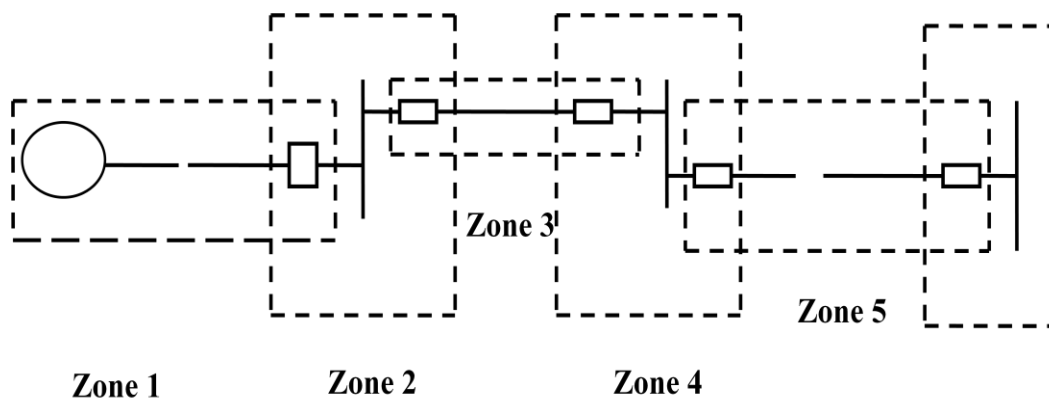

Fig.1.1 Zones of Protections

- The circuit Breakers are inserted between the component of of the zone and the rest of the power system. Thus, the location of the CBs helps to define the boundaries of the zones of protection.
- The neighbouring zones of protection are made to overlap so as to ensure that no part of the power system remains without protection. However, occurrence of fault with in the overlapped region would trip more number of circuit breakers than the minimum necessary to disconnect the faulty element

Protection System Requirements

- The fundamental requirements for a protection system areas follows:
 - Reliability: the ability of the protection to operate correctly. It has two basic elements-dependability, which is the certainty of a correct operation on the occurrence of a fault, and security ,which is the ability to avoid incorrect operation during faults.
 - Speed: minimum operating time to clear a fault in order to avoid damage to equipment.
 - Selectivity: maintaining continuity of supply by disconnecting the minimum section of the network necessary to isolate the fault. The property of selective tripping is also called ”discrimination” and is achieved by two general methods:
 - Time graded systems
 - Unit systems
 - Cost: maximum protection at the lowest cost possible

Primary and back-up Protection

- Primary Protection
 - The primary protection scheme ensures quick and selective clearing of the faults within the boundary of the circuit element it protects. Primary Protection as a rule is provided for each section of an electrical installation.

Causes of Failure of Primary Protection

Primary Protection may fail because of failure in any of the following:

1. Current or voltage supply to the relay.

2. D.C.tripping voltage supply
3. Protective relays
4. Tripping circuit
5. Circuit Breaker

- Back-up Protection

Back-up protection is the name given to a protection which backs the primary protection whenever the later fails in operation.

The back-up protection by definition is slower than the protection

The design of the back-up protection needs to be coordinated with the design of the primary protection

Circuit Breaker

Circuit breakers provide a manual means of energizing and de-energizing a circuit and automatic over current protection. Unlike fuses, which must be replaced when they open, a circuit breaker can be reset once the over current condition has been corrected. Pushing the handle to the “OFF” position then back to the “ON” position restores the circuit. If a circuit reopens upon reset to the “ON” position, the circuit should be checked by a qualified electrician.

Circuit Breaker Operation

In the following illustration, an AC motor is connected through a circuit breaker to a voltage source. When the circuit breaker is closed, a complete path for current exists between the voltage source and the motor allowing the motor to run. Opening the circuit breaker breaks the path of current flow and the motor stops. The circuit breaker automatically opens when it senses a fault. After the fault has been cleared, the breaker can be closed, allowing the motor to operate.

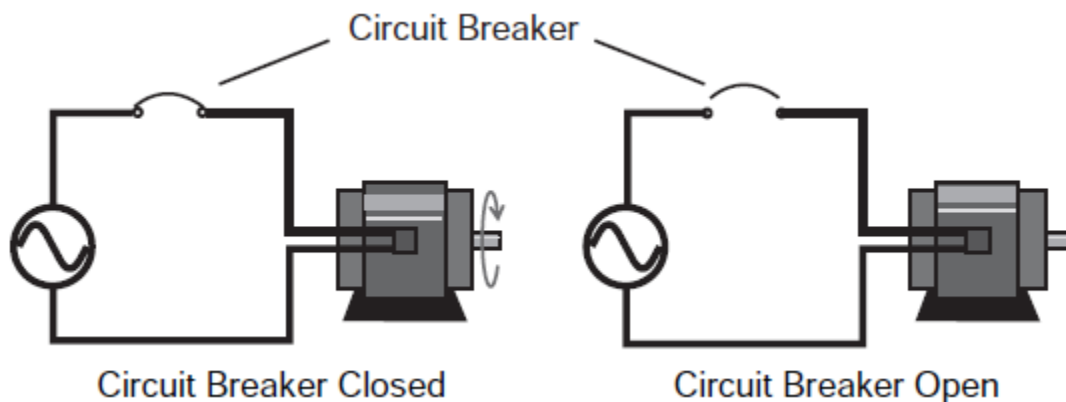

Fig. 1.2 Circuit Breaker operation during open and closed condition.

Formation of arc during circuit breaking

During opening of current carrying contacts in a circuit breaker the medium in between opening contacts become highly ionized through which the interrupting current gets low resistive path and continues to flow through this path even the contacts are physically separated. During the flowing of current from one contact to other the path becomes so heated that it glows. This is called **arc**.

Arc in Circuit Breaker

Whenever, on load current contacts of circuit breaker open there is an **arc in circuit breaker**, established between the separating contacts. As long as this arc is sustained in between the contacts the current through the circuit breaker will not be interrupted finally as because arc is itself a conductive path of electricity. For total interruption of current the circuit breaker it is essential to quench the arc as quick as possible. The main designing criteria of a circuit breaker is to provide appropriate technology of **arc quenching** in circuit breaker to fulfill quick and safe current interruption. So before going through different arc quenching techniques employed in circuit breaker, we should try to understand "e;what is arc"; and basic theory of **arc in circuit breaker**, let's discuss.

Thermal Ionization of Gas

There are numbers of free electrons and ions present in a gas at room temperature due to ultraviolet rays, cosmic rays and radioactivity of the earth. These free electrons and ions are so few in number that they are insufficient to sustain conduction of electricity. The gas molecules move randomly at room temperature. It is found an air molecule at a temperature of 300°K (Room temperature) moves randomly with an approximate average velocity of 500 meters/second and collides other molecules at a rate of 10^{10} times/second. These randomly moving molecules collide each other in very frequent manner but the kinetic energy of the molecules is not sufficient to extract an electron from atoms of the molecules. If the temperature is increased the air will be heated up and consequently the velocity on the molecules increased. Higher velocity means higher impact during inter molecular collision. During this situation some of the molecules are disassociated in to atoms. If temperature of the air is further increased many atoms are deprived of valence electrons and make the gas ionized. Then this ionized gas can conduct electricity because of sufficient free electrons. This condition of any gas or air is called plasma. This phenomenon is called **thermal ionization of gas**.

Ionization due to Electron Collision

As we discussed that there are always some free electrons and ions presents in the air or gas but they are insufficient to conduct electricity. Whenever these free electrons come across a strong electric field, these are directed towards higher potential points in the field and acquire sufficiently high velocity. In other words, the electrons are accelerated along the direction of the electric field due to high potential gradient. During their travel these electrons collide with other atoms and molecules of the air or gas and extract valance electrons from their orbits. After extracted from parent atoms, the electrons will also run along the direction of the same electric field due to potential gradient. These electrons will similarly collide with other atoms and create more free electrons which will also be directed along the electric field. Due to this conjugative action the numbers of free electrons in the gas will become so high that the gas starts conducting electricity. This phenomenon is known as **ionization of gas** due to electron collision.

Deionization of Gas

If all the cause of **ionization of gas** is removed from an ionized gas it rapidly come back to its neutral state by recombination of the positive and negative charges. The process of recombination of positive and negative charges is known as deionization process. In deionization by diffusion, the negative ions or electrons and positive ions move to the walls under the influence of concentration gradients and thus completing the process of recombination.

Role of Arc in Circuit Breaker

When two current contacts are just open, an arc bridges the contact gap through which the current gets a low resistive path to flow so there will not be any sudden interruption of current. As there is no sudden and abrupt change in current during opening of the contacts, there will not be any abnormal switching over voltage in the system. If i is the current flows through the contacts just before they open, L is the system inductance, switching over voltage during opening of contacts, may be expressed as $V = L.(di/dt)$ where di/dt rate of change of current with respect to time during opening of the contacts. In the case of alternating current arc is monetarily extinguished at every current zero. After crossing every current zero the media between separated contacts gets ionized again during next cycle of current and the arc in circuit breaker is reestablished. To make the interruption complete and successful, this re-ionization in between separated contacts to be prevented after a current zero.

If arc in circuit breaker is absent during opening of current carrying contacts, there would be sudden and abrupt interruption of current which will cause a huge switching overvoltage sufficient to severely stress the insulation of the system. On the other hand, the arc provides a gradual but quick, transition from the current carrying to the current breaking states of the contacts.

Arc Interruption or Arc Quenching or Arc Extinction Theory

Arc Column Characteristics

At high temperature the charged particles in a gas are rapidly and randomly move, but in absence of electric field, no net motion is occurred. Whenever an electric field is applied in the gas, the charged particles gain drift velocity superimposed on their random thermal motion. The drift velocity is proportional to the voltage gradient of the field and particle mobility. The particle mobility depends upon the mass of the particle, heavier particles, lower the mobility. The mobility also depends upon mean free paths available in the gas for random movement of the particles. Since every time a particle collides, it losses its directed velocity and has to be re-accelerated in the direction of electric field again. Hence net mobility of the particles is reduced. If the gas is in highly pressure, it becomes denser and hence, the gas molecules come closer to each other, therefore collision occurs more frequently which lowers the mobility particles. The total current by charged particles is directly proportional to their mobility. Therefore the mobility of charged particles depends upon the temperature, pressure of the gas and as well as nature of the gas. Again the mobility of gas particles determines the degree ionization of gas.

So from above explanation we can say that ionization process of gas depends upon nature of gas (heavier or lighter gas particles), pressure of gas and temperature of gas. As we said earlier the intensity of arc column depend up on the presence of ionized media between separated electrical contacts, hence, special attention should be given in reducing ionization or increasing deionization of media between contacts. That is why the main designing feature of circuit breaker is to provide different pressure control methods, cooling methods for different arc media in between circuit breaker contacts.

Heat loss from Arc

Heat loss from arc in circuit breaker is taken place through conduction, convection as well as radiation. In circuit breaker with plain break arc in oil, arc in chutes or narrow slots

nearly all the heat loss due to conduction. In air blast circuit breaker or in breaker where a gas flow is present between the electrical contacts, the heat loss of arc plasma occurs due to convection process. At normal pressure the radiation is not a significant factor but at higher pressure the radiation may become a very important factor of heat dissipation from arc plasma. During opening of electrical contacts, the arc in circuit breaker is produced and it is extinguished at every zero crossing of the current and then it is again reestablished during next cycle. The final arc extinction or arc quenching in circuit breaker is achieved by rapid increase of the dielectric strength in the medium between the contacts so that reestablishment of arc after zero crossing cannot be possible. This rapid increase of dielectric strength in between circuit breaker contacts is achieved either by deionization of gas in the arc media or by replacing ionized gas by cool and fresh gas.

There are various deionization processes applied for arc extinction in circuit breaker, let us discussed in brief.

Deionization of Gas due to Increasing Pressure

If pressure of the arc path increases, the density of the ionized gas is increased which means, the particles in the gas come closer to each other and as a result the mean free path of the particles is reduced. This increases the collision rate and as we discussed earlier at every collision the charged particles loss their directed velocity along electric field and again they are re-accelerated towards field. It can be said that over all mobility of the charged particles is reduced so the voltage required to maintain the arc is increased. Another effect of the increased density of particles is a higher rate of deionization of gas due to the recombination of oppositely charged particles.

Deionization of Gas due to Decreasing Temperature

The rate of ionization of gas depends upon the intensity of impact during collision of gas particles. The intensity of impact during collision of particles again depends upon velocity of random motions of the particles. This random motion of a particle and its velocity increases with increase of temperature of the gas. Hence it can be concluded like that if temperature of a gas is increased; its ionization process is increased and opposite statement is also true that is if the temperature is decreased the rate of ionization of gas is decreased means deionization of gas is increased. Therefore more voltage required to maintain arc plasma with a decreased temperature. Finally it can be said that the cooling effectively increases the resistance of the arc.

The insulating material (may be fluid or air) used in circuit breaker should serve two important functions. They are written as follows:

1. It should provide sufficient insulation between the contacts when breaker opens.
2. It should extinguish the arc occurring between the contacts when breaker opens.

The second point needs more explanation. To understand this point let us consider a situation if there is some fault or short circuit in the system, the relay provides desired signals to the circuit breaker so as to prevent system from ongoing fault. Now when circuit breaker opens its contacts, due to this an arc is drawn. The arc is interrupted by suitable insulator and technique.

Methods of Arc Interruption

There are two methods by which interruption is done.

1. High resistance method,
2. Low resistance method or zero interruption method.

In high interruption method we can increase the electrical resistance many times to such a high value that it forces the current to reach to zero and thus restricting the possibility of arc being re-struck. Proper steps must be taken in order to ensure that the rate at which the resistance is increased or decreased is not abnormal because it may lead to generation of harmful induced voltages in the system. The arc resistance can be increased by various methods like lengthening or cooling of the arc etc.

Limitations of high resistance method: Arc discharge has a resistive nature due to this most of the energy is received by circuit breaker itself hence proper care should be taken during the manufacturing of circuit breaker like mechanical strength etc. Therefore this method is applied in dc power circuit breaker, low and medium ac power circuit breaker. Low resistance method is applicable only for ac circuit and it is possible there because of presence of natural zero of current. The arc gets extinguished at the natural zero of the ac wave and is prevented from restricting again by rapid building of dielectric strength of the contact space. There are two theories which explain the phenomenon of arc extinction:

1. Energy balance theory,
2. Voltage race theory.

Before going in details about these theories, we should know the following terms.

- **Restriking voltage:** It may be defined as the voltage that appears across the breaking contact at the instant of arc extinction.
- **Recovery voltage :** It may be defined as the voltage that appears across the breaker contact after the complete removal of transient oscillations and final extinction of arc has resulted in all the poles.
- **Active recovery voltage :** It may be defined as the instantaneous recovery voltage at the instant of arc extinction.
- **Arc voltage :** It may be defined as the voltage that appears across the contact during the arcing period, when the current flow is maintained in the form of an arc. It assumes low value except for the point at which the voltage rise rapidly to a peak value and current reaches to zero.

1. **Energy Balance Theory:** When the contact of circuit breaker are about to open, restriking voltage is zero, hence generated heat would be zero and when the contacts are fully open there is infinite resistance this again make no production of heat. We can conclude from this that the maximum generated heat is lying between these two cases and can be approximated, now this theory is based on the fact that the rate of generation of heat between the contacts of circuit breaker is lower than the rate at which heat between the contact is dissipated. Thus if it is possible to remove the generated heat by cooling, lengthening and splitting the arc at a high rate the generation, arc can be extinguished.
2. **Voltage Race Theory:** The arc is due to the ionization of the gap between the contacts of the circuit breaker. Thus the resistance at the initial stage is very small i.e. when the contacts are closed and as the contact separates the resistance starts increasing. If we remove ions at the initial stage either by recombining them into neutral molecules or inserting insulation at a rate faster than the rate of ionisation, the arc can be interrupted. The ionisation at zero current depends on the voltage known as **restriking voltage**.

Let us define an expression for restriking voltage. For loss-less or ideal system we have, Here v = restriking voltage. V = value of voltage at the instant of interruption. L and C are series inductor and shunt capacitance up to fault point. Thus from above equation we can see that lower the value of product of L and C , higher the value of restriking voltage. The variation of v versus time is plotted in Fig. 1.3:

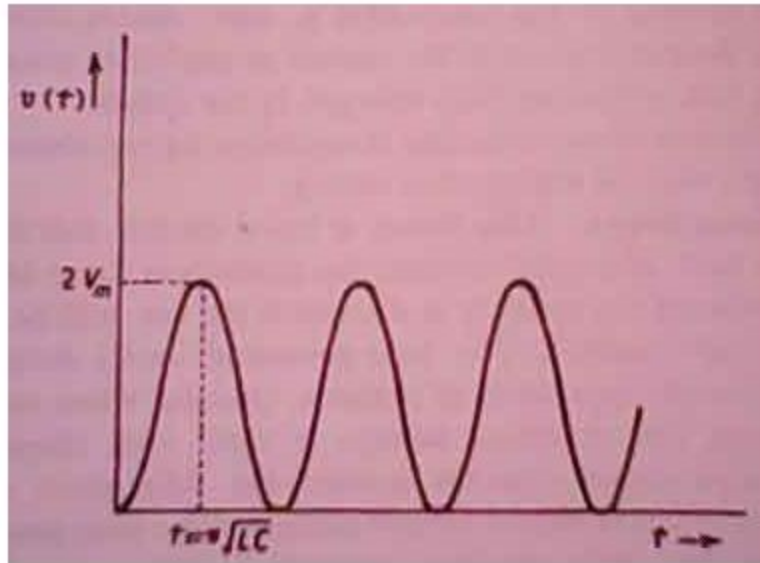

Fig. 1.3 Voltage across breaker contacts

Now let us consider a practical system, or assume there finite loss in the system. As shown in Fig. 1.4, in this case the restriking voltage is damped out due to the presence of some finite resistance. Here it is assumed that the current lags behind the voltage by an angle (measured in degrees) of 90. However in practical situation angle may varies depending upon time in cycle at which the fault is occurred.

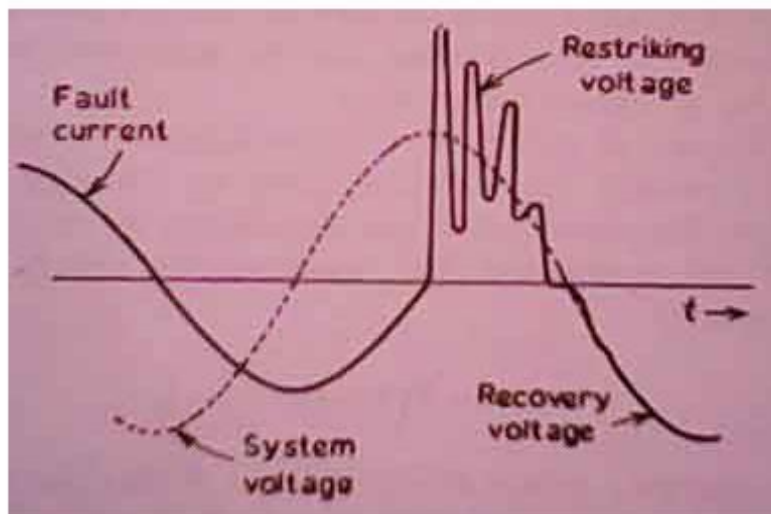

Fig. 1.4 Restriking voltage across breaker contacts

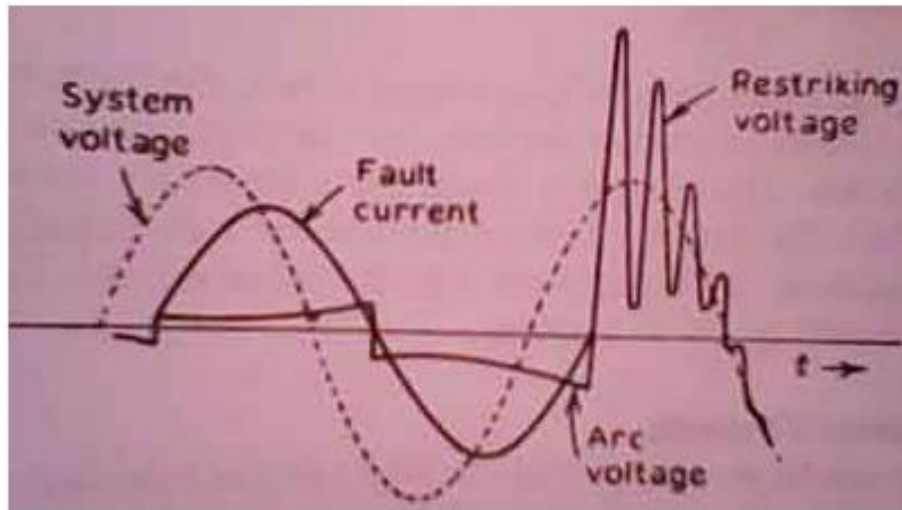

Fig. 1.5 Restriking voltage across breaker contacts along with fault current

Let us consider the effect of arc voltage, if arc voltage is included in the system, there is an increment in the restriking voltage. However this is offset by another effect of an arc voltage which opposes the current flow and making change in the phase of current, thus bringing it more into phase with the applied voltage. Hence the current is not at its peak value when voltage passes through zero value. **Rate of Rise of Restriking Voltage (RRRV):** It is defined as the ratio of peak value of restriking voltage to time taken to reach to peak value. It is one of the most important parameter as if the rate at which the dielectric strength developed between the contacts is greater than RRRV, and then the arc will be extinguishes.

Rating of Circuit Breaker

The **rating of a circuit breaker** includes,

- 1) Rated short circuit breaking current.
- 2) Rated short circuit making current.
- 3) Rated operating sequence of circuit breaker.
- 4) Rated short time current.

Short Circuit Breaking Current of Circuit Breaker

This is the maximum short circuit current which a circuit breaker can withstand before it is finally cleared by opening its contacts. When a short circuit flows through a circuit breaker, there would be thermal and mechanical stresses in the current carrying parts of the breaker. If the contact area and cross-section of the conducting parts of the circuit breaker are not sufficiently large, there may be a chance of permanent damage in insulation as well as conducting parts of the CB.

As per Joule's law of heating, the rising temperature is directly proportional to square of short circuit current, contact resistance and duration of short circuit current. The short circuit current continues to flow through circuit breaker until the short circuit is cleared by opening operation of the circuit breaker. As the thermal stress in the circuit breaker is proportional to the period of short circuit, the breaking capacity of electrical circuit breaker, depends upon the operating time.

At 160°C aluminum becomes soft and loses its mechanical strength, this temperature may be taken as limit of temperature rise of breaker contacts during short circuit.

Hence short circuit breaking capacity or **short circuit breaking current of circuit breaker** is defined as maximum current can flow through the breaker from time of occurring short circuit to the time of clearing the short circuit without any permanent damage in the CB. The value of short circuit breaking current is expressed in RMS. During short circuit, the CB is not only subjected to thermal stress, it also suffers seriously from mechanical stresses. So during determining short circuit capacity, the mechanical strength of the CB is also considered. So for choosing suitable circuit breaker it is obvious to determine the fault level at that point of the system where CB to be installed. Once the fault level of any part of electrical transmission is determined it is easy to choose the correct rated circuit breaker for this part of network.

Rated Short Circuit Making Capacity

The short circuit making capacity of circuit breaker is expressed in peak value not in rms value like breaking capacity. Theoretically at the instant of fault occurrence in a system, the fault current can rise to twice of its symmetrical fault level. At the instant of switching on a circuit breaker in faulty condition, of system, the short circuit portion of the system connected to the source. The first cycle of the current during a circuit is closed by circuit breaker, has maximum amplitude. This is about twice of the amplitude of symmetrical

fault current waveform. The breaker's contacts have to withstand this highest value of current during the first cycle of waveform when breaker is closed under fault. On the basis of this above mentioned phenomenon, a selected breaker should be rated with short circuit making capacity. As the rated **short circuit making current of circuit breaker** is expressed in maximum peak value, it is always more than rated short circuit breaking current of circuit breaker. Normally value of short circuit making current is 2.5 times more than short circuit breaking current.

Rated Operating Sequence or Duty Cycle of Circuit Breaker

This is mechanical duty requirement of circuit breaker operating mechanism. The sequence of rated operating duty of a circuit breaker has been specified as

O – t – CO – t' – CO

where O indicates opening operation of CB. CO represents closing operation immediately followed by an opening operation without any intentional time delay. 't' is time between two operations which is necessary to restore the initial conditions and / or to prevent undue heating of conducting parts of circuit breaker. $t = 0.3$ sec for circuit breaker intended for first auto re closing duty, if not otherwise specified. Suppose rated duty cycle of a circuit breaker is O – 0.3 sec – CO – 3 min – CO. This means, an opening operation of circuit breaker is followed by a closing operation after a time interval of 0.3 sec, then the circuit breaker again opens without any intentional time delay. After this opening operation the CB is again closed after 3 minutes and then instantly trips without any intentional time delay.

Rated Short Time Current

This is the current limit which a circuit breaker can carry safely for certain specific time without any damage in it.

The circuit breakers do not clear the short circuit current as soon as any fault occurs in the system. There always some intentional and an intentional time delays present between the instant of occurrence of fault and instant of clearing the fault by CB. This delay are because of time of operation of protection relays, time of operation of circuit breaker and also there may be some intentional time delay imposed in relay for proper coordination of power system protection. Even a circuit breaker fails to trip, the fault will be cleared by next higher positioned circuit breaker. In

this case the fault clearing time is longer. Hence, after fault, a circuit breaker has to carry the short circuit for certain time. The summation of all time delays should not be more than 3 seconds, hence a circuit breaker should be capable of carrying a maximum faulty current for at least this short period of time.

The short circuit current may have two major affects inside a circuit breaker.

1. Because of the high electric current, there may be high thermal stress in the insulation and conducting parts of C.B.
2. The high short circuit current, produces significant mechanical stresses in different current carrying parts of the circuit breaker.

A circuit breaker is designed to withstand these stresses. But no circuit breaker has to carry a short circuit current not more than a short period depending upon the coordination of protection. So it is sufficient to make C.B capable of withstanding affects of short circuit current for a specified short period.

The rated **short time current of a circuit breaker** is at least equal to rated short circuit breaking current of the circuit breaker.

Rated Voltage of Circuit Breaker

Rated voltage of circuit breaker depends upon its insulation system. For below 400 KV systems, the circuit breaker is designed to withstand 10% above the normal system voltage. For above or equal 400 KV system the insulation of circuit breaker should be capable of withstanding 5% above the normal system voltage. That means, rated voltage of circuit breaker corresponds to the highest system voltage. This is because during no load or small load condition the voltage level of power system is allowed rise up to highest voltage rating of the system.

A circuit breaker is also subject to two other high voltage conditions.

- 1) Sudden disconnection of huge load for any other cause, the voltage imposed on the CB and also between the contacts when the CB is open, may be very high compared to higher system voltage. This voltage may be of power frequency but does not stay for very long period as this high voltage situation must be cleared by protective switchgear.

But a circuit breaker may have to withstand this power frequency over voltage, during its normal life span. The Circuit Breaker must be rated for power frequency withstand voltage for a specific time only. Generally the time is 60 seconds. Making power frequency withstand capacity, more than 60 second is not economical and not practically desired as all the abnormal situations of electrical power system are definitely cleared within much smaller period than 60 seconds.

2) Like other apparatuses connected to power system, a circuit breaker may have also to face lightning impulse and switching impulses during its life span.

The insulation system of CB and contact gap of an open CB have to withstand these impulse voltage waveform amplitude of this disturbance is very high but extremely transient in nature. So a circuit breaker is designed to withstand this impulse peaky voltage for microsecond range only

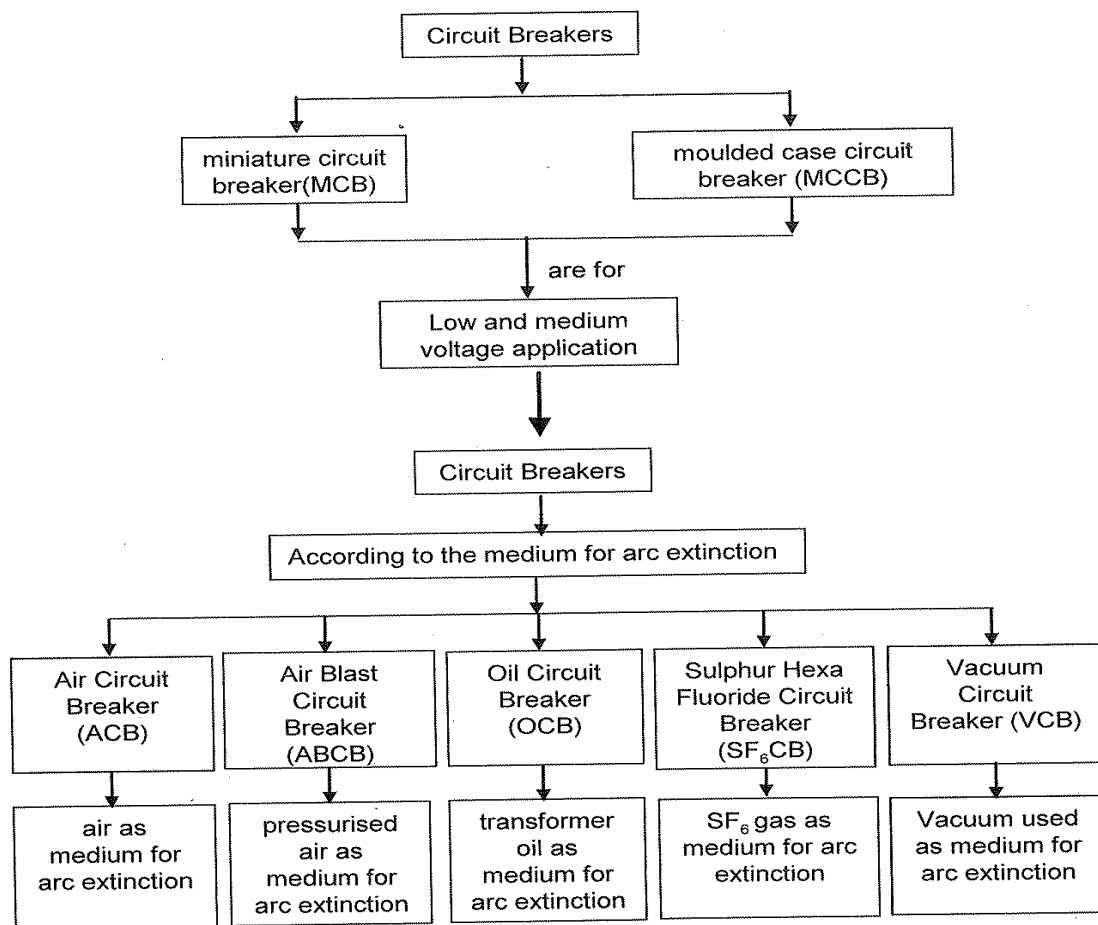

Fig. 1.6 Different types of Circuit Breakers

Air Circuit Breaker and Air Blast Circuit Breaker

This type of circuit breakers, is those kind of circuit breaker which operates in air at atmospheric pressure. After development of oil circuit breaker, the medium voltage **air circuit breaker** (ACB) is replaced completely by oil circuit breaker in different countries. But in countries like France and Italy, ACBs are still preferable choice up to voltage 15 KV. It is also good choice to avoid the risk of oil fire, in case of oil circuit breaker. In America ACBs were exclusively used for the system up to 15 KV until the development of new vacuum and SF₆ circuit breakers.

Working Principle of Air Circuit Breaker

The working principle of this breaker is rather different from those in any other types of circuit breakers. The main aim of all kind of circuit breaker is to prevent the reestablishment of arcing after current zero by creating a situation where in the contact gap will withstand the system recovery voltage. The **air circuit breaker** does the same but in different manner. For interrupting arc it creates an arc voltage in excess of the supply voltage. Arc voltage is defined as the minimum voltage required maintaining the arc. This circuit breaker increases the arc voltage by mainly three different ways,

1. It may increase the arc voltage by cooling the arc plasma. As the temperature of arc plasma is decreased, the mobility of the particle in arc plasma is reduced, hence more voltage gradient is required to maintain the arc.
2. It may increase the arc voltage by lengthening the arc path. As the length of arc path is increased, the resistance of the path is increased, and hence to maintain the same arc current more voltage is required to be applied across the arc path. That means arc voltage is increased.
3. Splitting up the arc into a number of series arcs also increases the arc voltage.

Types of ACB

There are mainly two types of ACB are available.

1. Plain air circuit breaker.
2. Air blast Circuit Breaker.

Operation of ACB

- The first objective is usually achieved by forcing the arc into contact with as large an area as possible of insulating material. Every air circuit breaker is fitted with a chamber surrounding the contact. This chamber is called 'arc chute'. The arc is driven into it. If inside of the arc chute is suitably shaped, and if the arc can be made conform to the shape, the arc chute wall will help to achieve cooling. This type of arc chute should be made from some kind of refractory material. High temperature plastics reinforced with glass fiber and ceramics are preferable materials for making arc chute.
- The second objective that is lengthening the arc path, is achieved concurrently with first objective. If the inner walls of the arc chute is shaped in such a way that the arc is not only forced into close proximity with it but also driven into a serpentine channel projected on the arc chute wall. The lengthening of the arc path increases the arc resistance.
- The third technique is achieved by using metal arc splitter inside the arc chute. The main arc chute is divided into numbers of small compartments by using metallic separation plates. These metallic separation plates are actually the arc splitters and each of the small compartments behaves as individual mini arc chute. In this system the initial arc is split into a number of series arcs, each of which will have its own mini arc chute. So each of the split arcs has its own cooling and lengthening effect due to its own mini arc chute and hence individual split arc voltage becomes high. These collectively, make the over all arc voltage, much higher than the system voltage.

This was **working principle of air circuit breaker** now we will discuss in details the operation of ACB in practice.

The air circuit breaker, operated within the voltage level 1 KV, does not require any arc control device. Mainly for heavy fault current on low voltages (low voltage level above 1 KV) ABCs with appropriate arc control device, are good choice. These breakers normally have two pairs of contacts. The main pair of contacts carries the current at normal load and these contacts are made of copper. The additional pair is the arcing contact and is made of carbon. When circuit breaker is being opened, the main contacts open first and during opening of main contacts the arcing contacts are still in touch with each other. As the current gets, a parallel low resistive path through the arcing contact during opening of main contacts, there will not be any arcing in the

main contact. The arcing is only initiated when finally the arcing contacts are separated. The each of the arc contacts is fitted with an arc runner which helps, the arc discharge to move upward due to both thermal and electromagnetic effects as shown in the figure.

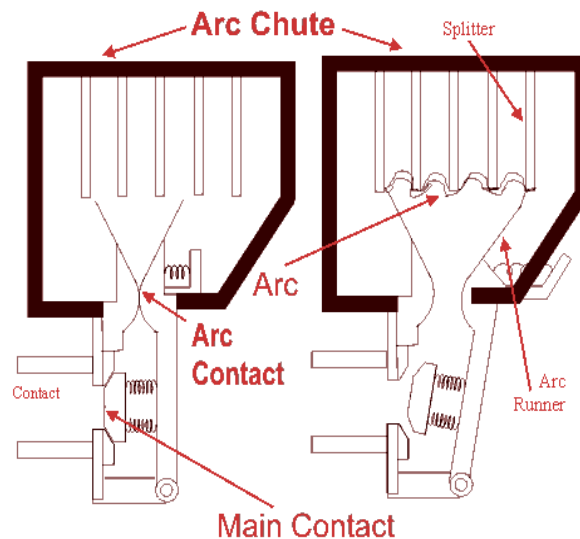

Fig. 1.7 Air Circuit Breaker

As the arc is driven upward it enters in the arc chute, consisting of splitters. The arc in chute will become colder, lengthen and split hence arc voltage becomes much larger than system voltage at the time of **operation of air circuit breaker**, and therefore the arc is quenched finally during the current zero.

Although this type of circuit breakers have become obsolete for medium voltage application, but they are still preferable choice for high current rating in low voltage application.

Air Blast Circuit Breaker

These **types of air circuit breaker** were used for the system voltage of 245 KV, 420 KV and even more, especially where faster breaker operation was required. Air blast circuit breaker has some specific advantages over oil circuit breaker which are listed as follows,

1. There is no chance of fire hazard caused by oil.
2. The breaking speed of circuit breaker is much higher during **operation of air blast circuit breaker**.
3. Arc quenching is much faster during **operation of air blast circuit breaker**.
4. The duration of arc is same for all values of small as well as high currents interruptions.

5. As the duration of arc is smaller, so lesser amount of heat realized from arc to current carrying contacts hence the service life of the contacts becomes longer.
6. The stability of the system can be well maintained as it depends on the speed of operation of circuit breaker.
7. Requires much less maintenance compared to oil circuit breaker.

There are also some disadvantages of air blast circuit breakers-

1. In order to have frequent operations, it is necessary to have sufficiently high capacity air compressor.
2. Frequent maintenance of compressor, associated air pipes and automatic control equipments is also required.
3. Due to high speed current interruption there is always a chance of high rate of rise of re-striking voltage and current chopping.
4. There also a chance of air pressure leakage from air pipes junctions.

As we said earlier that there are mainly two types of ACB, plain air circuit breaker and air blast circuit breaker. But the later can be sub divided further into three different categories.

1. Axial Blast ACB.
2. Axial Blast ACB with side moving contact.
3. Cross Blast ACB.

Axial Blast Air Circuit Breaker

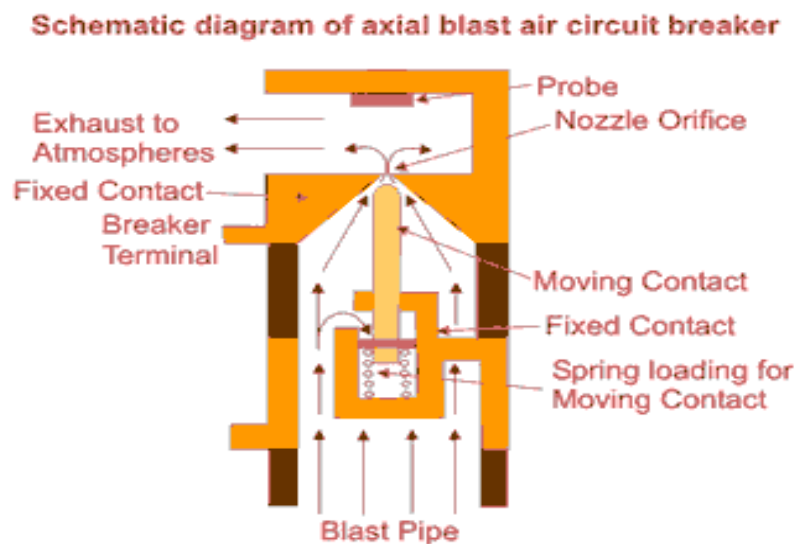

Fig. 1.8 Axial Blast ACB

In axial blast ACB the moving contact is in contact with fixed contact with the help of a spring pressure as shown in the figure. There is a nozzle orifice in the fixed contact which is blocked by tip of the moving contact at normal closed condition of the breaker. When fault occurs, the high pressure air is introduced into the arcing chamber. The air pressure will counter the spring pressure and deforms the spring hence the moving contact is withdrawn from the fixed contact and nozzle hole becomes open. At the same time the high pressure air starts flowing along the arc through the fixed contact nozzle orifice. This axial flow of air along the arc through the nozzle orifice will make the arc lengthen and colder hence arc voltage become much higher than system voltage that means system voltage is insufficient to sustain the arc consequently the arc is quenched.

circuit breaker with side moving contact” title=”Axial Blast Air Circuit Breaker with side moving contact” class=”alignleft”/>>

Axial Blast ACB with Side Moving Contact

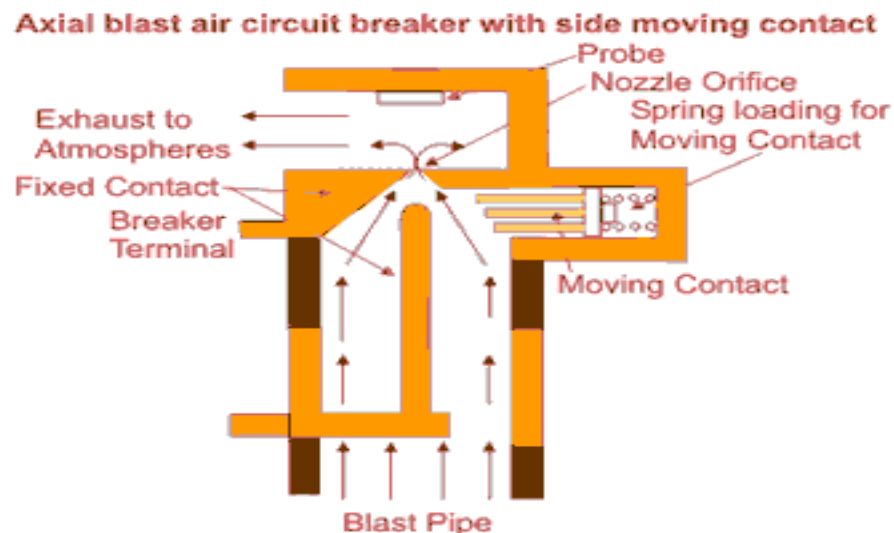

Fig. 1.9 Axial Blast side movement ACB

In this type of axial blast air circuit breaker the moving contact is fitted over a piston supported over a spring. In order to open the circuit breaker the air is admitted into the arcing chamber when pressure reaches to a predetermined value, it presses down the moving contact; an arc is

drawn between the fixed and moving contacts. The air blast immediately transfers the arc to the arcing electrode and is consequently quenched by the axial flow of air.

Cross Blast Air Circuit Breaker

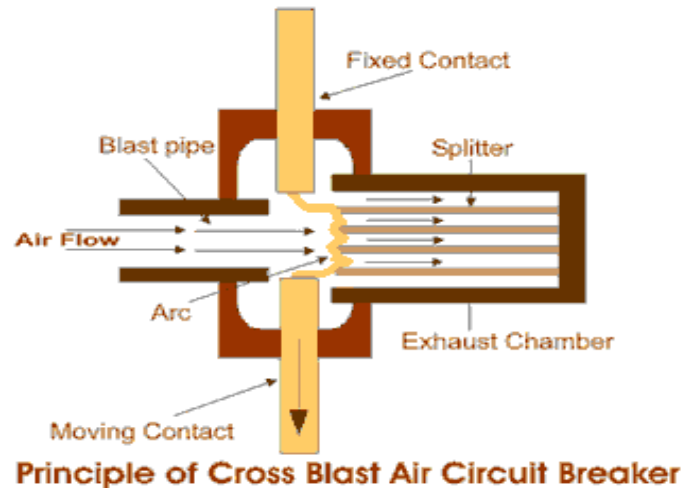

Fig. 1.10 Cross Blast ACB

The working principle of cross blast air circuit breaker is quite simple. In this system of air blast circuit breaker the blast pipe is fixed in perpendicular to the movement of moving contact in the arcing chamber and on the opposite side of the arcing chamber one exhaust chamber is also fitted at the same alignment of blast pipe, so that the air comes from blast pipe can straightly enter into exhaust chamber through the contact gap of the breaker. The exhaust chamber is spit with arc splitters. When moving contact is withdrawn from fixed contact, an arc is established in between the contact, and at the same time high pressure air coming from blast pipe will pass through the contact gap and will forcefully take the arc into exhaust chamber where the arc is split with the help of arc splitters and ultimately arc is quenched.

Minimum Oil Circuit Breaker or MOCB

These types of circuit breakers utilize oil as the interrupting media. However, unlike **bulk oil circuit breaker**, a **minimum oil circuit breaker** places the interrupting unit in insulating chamber at live potential. The insulating oil is available only in interrupting chamber. The feature of designing **MOCB** is to reduce requirement of oil, and hence these breaker are called **minimum oil circuit breaker**.

As the volume of the oil in bulk oil circuit breaker is huge, the chances of fire hazard in bulk oil system are more. For avoiding unwanted fire hazard in the system, one important development in the design of oil circuit breaker has been introduced where use of oil in the circuit breaker is much less than that of bulk oil circuit breaker. It has been decided that the oil in the circuit breaker should be used only as arc quenching media not as an insulating media. Then the concept of **minimum oil circuit breaker** comes. In this type of circuit breaker the arc interrupting device is enclosed in a tank of insulating material which as a whole is at live potential of system. This chamber is called arcing chamber or interrupting pot. The gas pressure developed in the arcing chamber depends upon the current to be interrupted. Higher the current to be interrupted causes larger the gas pressure developed inside the chamber, hence better the arc quenching. But this put a limit on the design of the arc chamber for mechanical stresses. With use of better insulating materials for the arcing chambers such as glass fiber, reinforced synthetic resin etc, the **minimum oil circuit breaker** are able to meet easily the increased fault levels of the system.

Working Principle or Arc Quenching in Minimum Oil Circuit Breaker

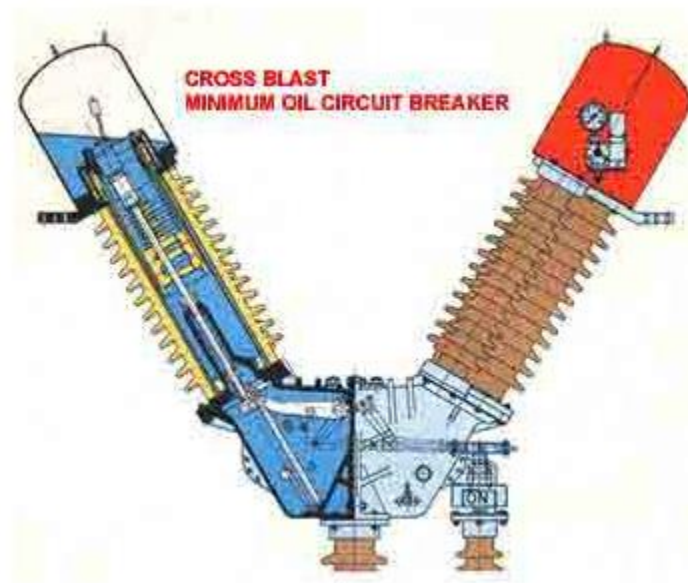

Fig. 1.11 Minimum Oil Circuit Breaker

Working Principle of minimum oil circuit breaker or arc quenching in minimum oil circuit breaker is described below. In a **minimum oil circuit breaker**, the arc drawn across the current carrying contacts is contained inside the arcing chamber.

Hence the hydrogen bubble formed by the vaporized oil is trapped inside the chamber. As the contacts continue to move, after its certain travel an exit vent becomes available for exhausting the trapped hydrogen gas. There are two different types of arcing chamber is available in terms of venting are provided in the arcing chambers. One is axial venting and other is radial venting. In axial venting, gases (mostly Hydrogen), produced due to vaporization of oil and decomposition of oil during arc, will sweep the arc in axial or longitudinal direction.

Let's have a look on **working principle Minimum Oil Circuit Breaker** with axial venting arc chamber. The moving contact has just been separated and arc is initiated in **MOCB**.

The ionized gas around the arc sweep away through upper vent and cold oil enters into the arcing chamber through the lower vent in axial direction as soon as the moving contact tip crosses the lower vent opening and final **arc quenching in minimum oil circuit breaker** occurs the cold oil occupies the gap between fixed contact and moving contact and the minimum oil circuit breaker finally comes into open position. Whereas in case of radial venting or cross blast, the gases (mostly Hydrogen) sweep the arc in radial or transverse direction. The axial venting generates high gas pressure and hence has high dielectric strength, so it is mainly used for interrupting low current at high voltage. On the other hand radial venting produces relatively low gas pressure and hence low dielectric strength so it can be used for low voltage and high current interruption. Many times the combination of both is used in minimum oil circuit breaker so that the chamber is equally efficient to interrupt low current as well as high current. These types of circuit breaker are available up to 8000 MVA at 245 KV.

Vacuum Circuit Breaker or VCB

A **vacuum circuit breaker** is such kind of circuit breaker where the arc quenching takes place in vacuum. The technology is suitable for mainly medium voltage application. For higher voltage vacuum technology has been developed but not commercially viable. The operation of opening and closing of current carrying contacts and associated arc interruption take place in a vacuum chamber in the breaker which is called vacuum interrupter. The vacuum interrupter consists of a steel arc chamber in the centre symmetrically arranged ceramic insulators. The vacuum pressure inside a vacuum interrupter is normally maintained at 10^{-6} bar. The material used for current carrying contacts plays an important role in the performance of the **vacuum circuit breaker**. CuCr is the most ideal material to make VCB contacts. Vacuum

interrupter technology was first introduced in the year of 1960. But still it is a developing technology. As time goes on, the size of the vacuum interrupter is being reducing from its early 1960's size due to different technical developments in this field of engineering. The contact geometry is also improving with time, from butt contact of early days it gradually changes to spiral shape, cup shape and axial magnetic field contact. The **vacuum circuit breaker** is today recognized as most reliable current interruption technology for medium voltage switchgear. It requires minimum maintenance compared to other circuit breaker technologies.

Advantages of Vacuum Circuit Breaker or VCB

Service life of vacuum circuit breaker is much longer than other types of circuit breakers. There is no chance of fire hazard as oil circuit breaker. It is much environment friendly than SF₆ Circuit breaker. Beside of that contraction of VCB is much user friendly. Replacement of vacuum interrupter (VI) is much convenient.

Operation of Vacuum Circuit Breaker

The main aim of any circuit breaker is to quench arc during current zero crossing, by establishing high dielectric strength in between the contacts so that reestablishment of arc after current zero becomes impossible. The dielectric strength of vacuum is eight times greater than that of air and four times greater than that of SF₆ gas. This high dielectric strength makes it possible to quench a vacuum arc within very small contact gap. For short contact gap, low contact mass and no compression of medium the drive energy required in vacuum circuit breaker is minimum. When two face to face contact areas are just being separated to each other, they do not be separated instantly, contact area on the contact face is being reduced and ultimately comes to a point and then they are finally de-touched. Although this happens in a fraction of micro second but it is the fact. At this instant of de-touching of contacts in a vacuum, the current through the contacts concentrated on that last contact point on the contact surface and makes a hot spot. As it is vacuum, the metal on the contact surface is easily vaporized due to that hot spot and create a conducting media for arc path. Then the arc will be initiated and continued until the next current zero.

At current zero this vacuum arc is extinguished and the conducting metal vapor is re-condensed on the contact surface. At this point, the contacts are already separated hence there is no question of re-vaporization of contact surface, for next cycle of current. That means, the arc cannot be reestablished again. In this way vacuum circuit breaker prevents the reestablishment of arc by

producing high dielectric strength in the contact gap after current zero. There are two types of arc shapes. For interrupting current up to 10 kA, the arc remains diffused and the form of vapor discharge and cover the entire contact surface. Above 10 kA the diffused arc is constricted considerably by its own magnetic field and it contracts. The phenomenon gives rise over heating of contact at its center. In order to prevent this, the design of the contacts should be such that the arc does not remain stationary but keeps travelling by its own magnetic field. Specially designed contact shape of vacuum circuit breaker make the constricted stationary arc travel along the surface of the contacts, thereby causing minimum and uniform contact erosion.

SF₆ Circuit Breaker

A circuit breaker in which the current carrying contacts operate in sulphur hexafluoride or SF₆ gas is known as an **SF₆ circuit breaker**. SF₆ has excellent insulating property. SF₆ has high electro-negativity. That means it has high affinity of absorbing free electron. Whenever a free electron collides with the SF₆ gas molecule, it is absorbed by that gas molecule and forms a negative ion. The attachment of electron with SF₆ gas molecules may occur in two different ways,



These negative ions obviously much heavier than a free electron and therefore over all mobility of the charged particle in the SF₆ gas is much less as compared other common gases. We know that mobility of charged particle is majorly responsible for conducting current through a gas.



Fig. 1.12 A SF₆ Circuit Breaker

Hence, for heavier and less mobile charged particles in SF₆ gas, it acquires very high dielectric strength. Not only the gas has a good dielectric strength but also it has the unique property of fast recombination after the source energizing the spark is removed. The gas has also very good heat transfer property. Due to its low gaseous viscosity (because of less molecular mobility) SF₆ gas can efficiently transfer heat by convection. So due to its high dielectric strength and high cooling effect SF₆ gas is approximately 100 times more effective arc quenching media than air. Due to these unique properties of this gas **SF₆ circuit breaker** is used in complete range of medium voltage and high voltage electrical power system. These circuit breakers are available for the voltage ranges from 33KV to 800KV and even more.

Disadvantages of SF₆ CB

The SF₆ gas is identified as a greenhouse gas, safety regulation are being introduced in many countries in order to prevent its release into atmosphere. Puffer type design of SF₆ CB needs a high mechanical energy which is almost five times greater than that of oil circuit breaker.

Types of SF₆ Circuit Breaker

There are mainly three types of SF₆ CB depending upon the voltage level of application-

1. Single interrupter SF₆ CB applied for up to 245 KV(220 KV) system.
2. Two interrupter SF₆ CB applied for up to 420 KV(400 KV) system.
3. Four interrupter SF₆ CB applied for up to 800 KV(715 KV) system.

Working of SF₆ Circuit Breaker

The working of SF₆ CB of first generation was quite simple it is some extent similar to air blast circuit breaker. Here SF₆ gas was compressed and stored in a high pressure reservoir. During **operation of SF₆ circuit breaker** this highly compressed gas is released through the arc in breaker and collected to relatively low pressure reservoir and then it pumped back to the high pressure reservoir for re utilize.

The **working of SF₆ circuit breaker** is little bit different in modern time. Innovation of puffer type design makes operation of SF₆ CB much easier. In buffer type design, the arc energy is utilized to develop pressure in the arcing chamber for arc quenching. Here the breaker is filled with SF₆ gas at rated pressure. There are two fixed contact fitted with a specific contact gap. A sliding cylinder bridges these to fixed contacts. The cylinder can axially slide upward and downward along the contacts. There is one stationary piston inside the cylinder which is fixed

with other stationary parts of the SF₆ circuit breaker, in such a way that it cannot change its position during the movement of the cylinder. As the piston is fixed and cylinder is movable or sliding, the internal volume of the cylinder changes when the cylinder slides.

During opening of the breaker the cylinder moves downwards against position of the fixed piston hence the volume inside the cylinder is reduced which produces compressed SF₆ gas inside the cylinder. The cylinder has numbers of side vents which were blocked by upper fixed contact body during closed position. As the cylinder move further downwards, these vent openings cross the upper fixed contact, and become unblocked and then compressed SF₆ gas inside the cylinder will come out through this vents in high speed towards the arc and passes through the axial hole of the both fixed contacts. The arc is quenched during this flow of SF₆ gas.

During closing of the circuit breaker, the sliding cylinder moves upwards and as the position of piston remains at fixed height, the volume of the cylinder increases which introduces low pressure inside the cylinder compared to the surrounding. Due to this pressure difference SF₆ gas from surrounding will try to enter in the cylinder. The higher pressure gas will come through the axial hole of both fixed contact and enters into cylinder via vent and during this flow; the gas will quench the arc.

D.C circuit breakers

Miniature circuit breakers available for use in direct current

Nowadays we use more commonly **miniature circuit breaker** or **MCB** in low voltage electrical network instead of fuse. The **MCB** has some advantages compared to fuse.

1. It automatically switches off the electrical circuit during abnormal condition of the network means in over load condition as well as faulty condition. The fuse does not sense but **miniature circuit breaker** does it in more reliable way. MCB is much more sensitive to over current than fuse.
2. Another advantage is, as the switch operating knob comes at its off position during tripping, the faulty zone of the electrical circuit can easily be identified. But in case of fuse, fuse wire should be checked by opening fuse grip or cutout from fuse base, for confirming the blow of fuse wire.
3. Quick restoration of supply cannot be possible in case of fuse as because fuses have to be

replaced for restoring the supply. But in the case of MCB, quick restoration is possible by just switching on operation.

4. Handling MCB is more electrically safe than fuse.

Because of too many advantages of MCB over fuse units, in modern low voltage electrical network, miniature circuit breaker is mostly used instead of backdated fuse unit. Only one disadvantage of MCB over fuse is that this system is more costly than fuse unit system.

Working Principle Miniature Circuit Breaker

There are two arrangement of **operation of miniature circuit breaker**. One due to thermal effect of over current and other due to electromagnetic effect of over current. The thermal **operation of miniature circuit breaker** is achieved with a bimetallic strip whenever continuous over current flows through MCB, the bimetallic strip is heated and deflects by bending. This deflection of bimetallic strip releases mechanical latch. As this mechanical latch is attached with operating mechanism, it causes to open the miniature circuit breaker contacts. But during short circuit condition, sudden rising of current, causes electromechanical displacement of plunger associated with tripping coil or solenoid of MCB. The plunger strikes the trip lever causing immediate release of latch mechanism consequently open the circuit breaker contacts. This was a simple explanation of **miniature circuit breaker working principle**.

Miniature Circuit Breaker Construction

Miniature circuit breaker construction is very simple, robust and maintenance free. Generally a MCB is not repaired or maintained, it just replaced by new one when required. A miniature circuit breaker has normally three main constructional parts. These are:

Frame of Miniature Circuit Breaker

The frame of miniature circuit breaker is a molded case. This is a rigid, strong, insulated housing in which the other components are mounted.

Operating Mechanism of Miniature Circuit Breaker

The operating mechanism of miniature circuit breaker provides the means of manual opening and closing operation of miniature circuit breaker. It has three-positions “ON,” “OFF,” and “TRIPPED”. The external switching latch can be in the “TRIPPED” position, if the MCB is tripped due to over-current. When manually switch off the MCB, the switching latch will be in

“OFF” position. In close condition of MCB, the switch is positioned at “ON”. By observing the positions of the switching latch one can determine the condition of MCB whether it is closed, tripped or manually switched off.

Trip Unit of Miniature Circuit Breaker

The trip unit is the main part, responsible for proper **working of miniature circuit breaker**. Two main types of trip mechanism are provided in MCB. A bimetal provides protection against over load current and an electromagnet provides protection against short-circuit current.

Operation of Miniature Circuit Breaker

There are three mechanisms provided in a single miniature circuit breaker to make it switched off. If we carefully observe the picture beside, we will find there are mainly one bi – metallic strip, one trip coil and one hand operated on – off lever. Electric current carrying path of a miniature circuit breaker shown in the picture is like follows. First left hand side power terminal – then bimetallic strip – then current coil or trip coil – then moving contact – then fixed contact and – lastly right had side power terminal. All are arranged in series.

If circuit is overloaded for long time, the bi – metallic strip becomes over heated and deformed. This deformation of bi metallic strip causes, displacement of latch point. The moving contact of the MCB is so arranged by means of spring pressure, with this latch point, that a little displacement of latch causes, release of spring and makes the moving contact to move for opening the MCB. The current coil or trip coil is placed such a manner, that during short circuit fault the mmf of that coil causes its plunger to hit the same latch point and make the latch to be displaced. Hence the MCB will open in same manner. Again when operating lever of the miniature circuit breaker is operated by hand, that means when we make the MCB at off position manually, the same latch point is displaced as a result moving contact separated from fixed contact in same manner. So, whatever may be the operating mechanism, that means, may be due to deformation of bi – metallic strip, due to increased mmf of trip coil or may due to manual operation, actually the same latch point is displaced and same deformed spring is released, which ultimately responsible for movement of the moving contact. When the the moving contact separated from fixed contact, there may be a high chance of arc.

MODULE- II

Relay Classification

Protection relays can be classified in accordance with their construction, the incoming signal and function

Construction

- Electromechanical
- Solid State
- Microprocessor
- Numerical

Incoming Signal

- Current
- Voltage
- Power
- Frequency
- Temperature
- Pressure
- Speed
- Others

Function

- Overcurrent
- Directional Overcurrent
- Distance
- Over voltage
- Differential
- Reverse Power

- Others

Electromechanical Relays

These relays are constructed with electrical, magnetic & mechanical components & have an operating coil & various contacts, & are very robust & reliable. Based on the construction, characteristics, these are classified in three groups.

Attraction Relays

Attraction relays can be AC & DC and operate by the movement of a piece of iron when it is attracted by the magnetic field produced by a coil. There are two main types of relays:

1. The attracted armature type
2. Solenoid type relay

Attracted Armature Relays

- Consists of a bar or plate (made of iron) that pivots when it is attracted towards the coil.
- The armature carries the moving part of the contact, which is closed or opened, according to the design, when the armature is attracted to the coil.

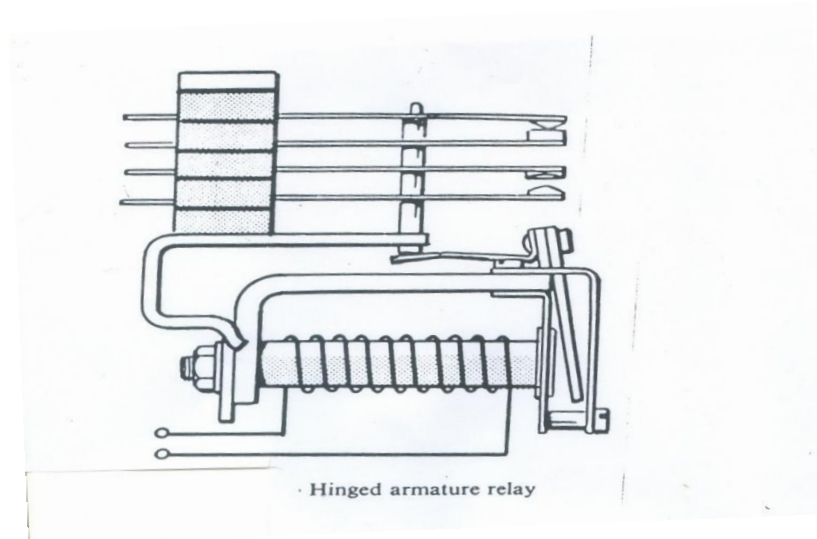

Fig. 2.1 Hinged Armature Relay

Solenoid Type Relays

In this a plunger or a piston is attracted axially within the field of the solenoid. In this case, the piston carries the moving contacts.

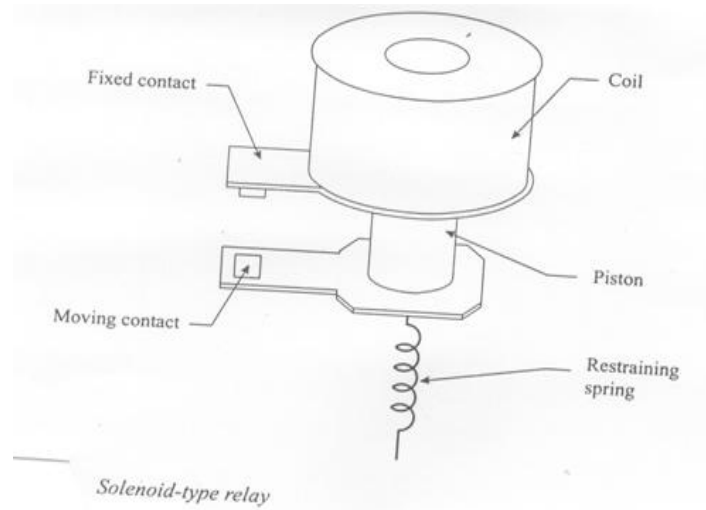

Fig. 2.2 Solenoid-type Relay

The force of attraction = $K_1 I^2 - K_2$

Where, K_1 depends on

- The number of turns of the coil
- The air gap
- The effective area
- The reluctance of the magnetic circuit

K_2 is the restraining force, usually produced by spring

For threshold or balanced condition, the resultant force is zero.

$$K_1 I^2 = K_2$$

$$I = \sqrt{\left(\frac{K_1}{K_2}\right)} \quad (2.1)$$

In order to control the value of current at which relay operates, the parameters K_1 and K_2 may be adjusted. Attraction relays effectively have no time-delay and are widely used when instantaneous operation is required

Relays with Movable Coils

This type of relay consists of a rotating movement with a small coil suspended or pivoted with the freedom to rotate between the poles of a permanent magnet.

The coil is restrained by two special springs which also serve as connections to carry the current to the coil

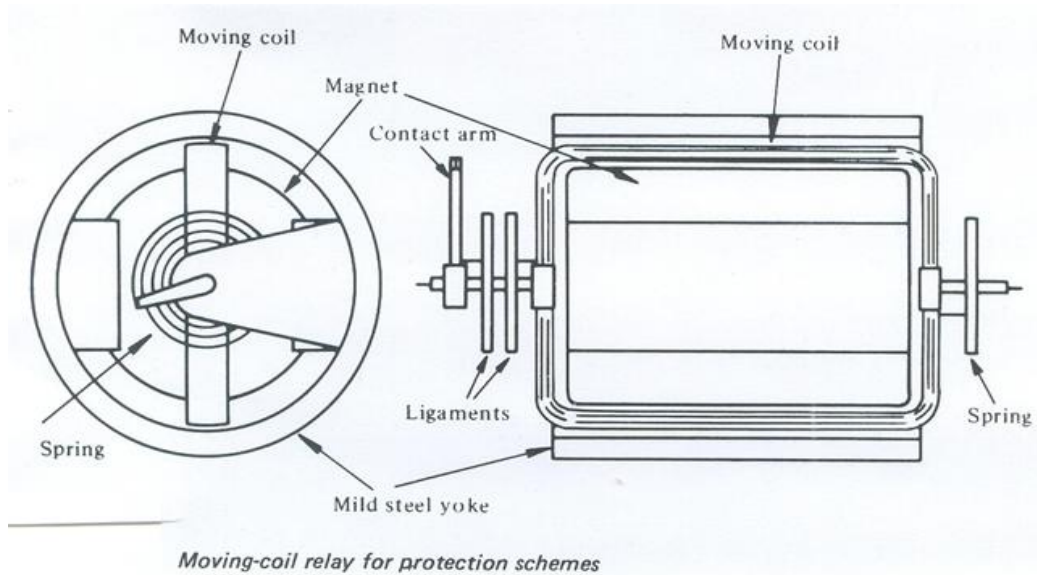

Fig. 2.3 Moving-coil relay

The torque produced in the coil is

$$T = B l a N i \quad (2.2)$$

where,

T= Torque, B= flux density, l= length of the coil, a= distance between the two sides of the coil

i=current flowing through the coil , N=number of turns in the coil

- The relay has inverse type characteristic

Induction Relays

- An induction relay works only with AC
- It consists of an electromagnetic system Which operates on a moving conductor, generally in the form of a DISC or CUP

Production of Actuating Torque

Various quantities are shown at instant when

- Both fluxes are directed downward

- Are increasing in magnitude

Let

$$\phi_1(t) = \phi_{m1} \sin(\omega t)$$

$$\phi_2(t) = \phi_{m2} \sin(\omega t + \theta)$$

It may be assumed with negligible error that the paths in which rotor current flow have negligible self inductance.

$$F = F_2 - F_1 \quad (2.2)$$

$$= \alpha \phi_2(t) i_{\phi 1}(t) - \phi_1(t) i_{\phi 2}(t)$$

$$= \alpha \phi_{m1} \phi_{m2} [\sin(\omega t + \theta) \cos(\omega t) - \sin(\omega t) \cos(\omega t + \theta)]$$

$$= \alpha \phi_{m1} \phi_{m2} \sin \theta$$

Since sinusoidal flux waves are assumed, we may substitute the rms values of the fluxes for the crest values in the above equation.

- It may be noted that the net force is same at every instant.
- The net force is directed from the point where the leading flux pierces the rotor towards the point where the lagging flux pierces the rotor.
- Actuating force is produced in the presence of out of phase fluxes.
- Maximum force is produced when $\theta=90^\circ$

Classification Of Induction Relays

1. Shaded pole relay

2. Watt-hour- meter type relay

3. Cup type relay

- The air gap flux produced by the current flowing in a single coil is split into two out of phase components by a so called 'Shading Ring' generally of copper, that encircles part of the pole face of each pole at the air gap.

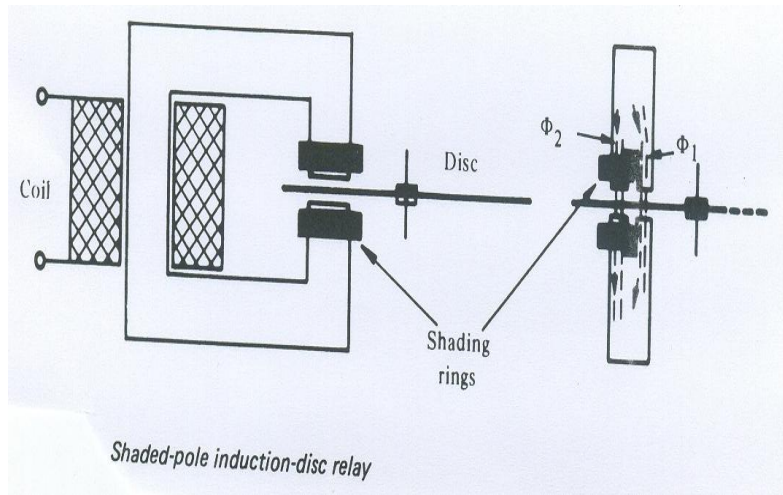

Fig.2.3 Shaded-pole induction relay

- The shading ring may be replaced by coils if control of operation of the shaded pole relay is desired.
- The inertia of the disc provides the time delay characteristics.

Watt Hour –Meter Structure

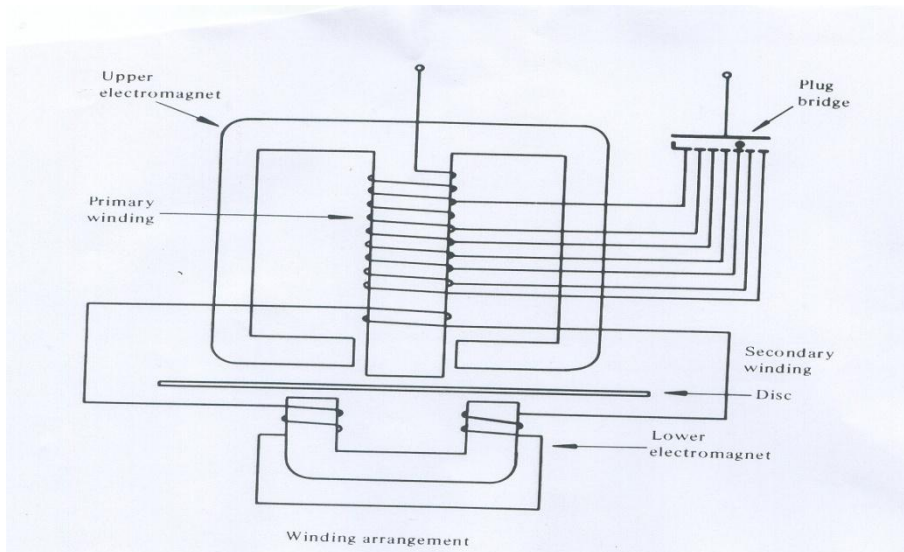

Fig.2.4 Watt-hour meter relay

- This structure gets its name from the fact that it is used in watt hour meters.
- It contains two separate coils on two different magnetic circuit, each of which produces one of two necessary fluxes for driving the rotor, which is also a disc

Induction-Cup

- This type of relay has a cylinder similar to a cup which can rotate in the annular air gap between the poles & the fixed central core.
- The operation of this relay is similar to that of an induction motor with salient poles for the windings of the stator

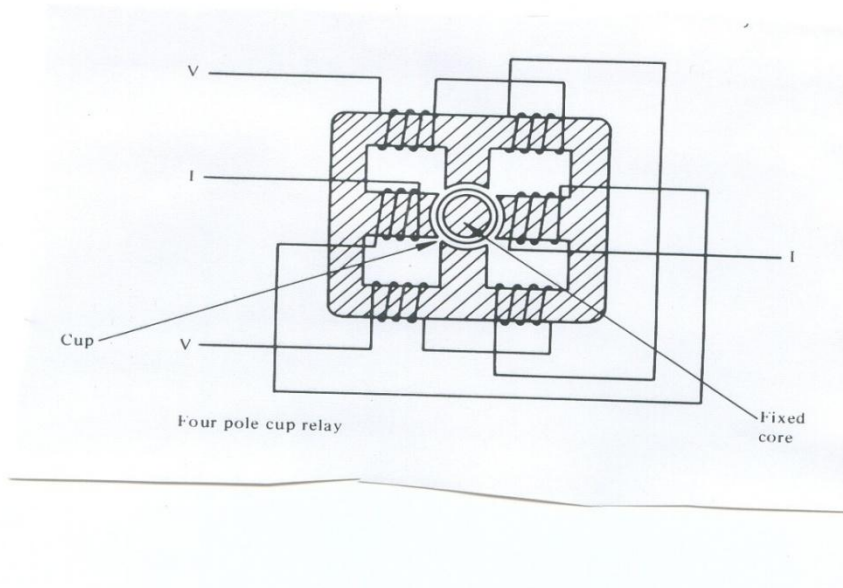

Fig.2.5 Induction-cup type relay

- The movement of the cup is limited to a small amount by the contact & the stops.
- A special spring provides restraining torque.
- The cup type of relay has a small inertia & is therefore principally used when high speed operation is required, for example in instantaneous units.

Over-current Relays

- Protection against excess current was naturally the earliest protection systems to evolve
- From this basic principle has been evolved the graded over current system, a discriminate fault protection.
- “Over current” protection is different from “over load protection”.
- Overload protection makes use of relays that operate in a time related in some degree to the thermal capability of the plant to be protected.
- Over current protection, on the other hand, is directly entirely to the clearance of the faults, although with the settings usually adopted some measure of overload protection is obtained.

Types of over current Relays

- Based on the relay operating characteristics , over current relays can be classified into three groups
 - Definite current or instantaneous
 - Definite time
 - Inverse time

Definite-Current Relays

- This type of relay operates instantaneously when the current reaches a predetermined value.

Definite Time Current Relays

- This type of relay operates after a definite time when the current reaches a pre-determined value.

Inverse Time Relays

- The fundamental property of these relays is that they operate in a time that is inversely proportional to the fault current. Inverse time relays are generally classified in accordance with their characteristic curve that indicates the speed of operation.
- Inverse-time relays are also referred as inverse definite minimum time or IDMT over-current relays

Setting the Parameters of Time Delay Over-current Relay

Pick-up setting

- The pick-up setting, or plug setting, is used to define the pick-up current of the relay, and fault currents seen by the relay are expressed as multiples of plug setting.
- Plug setting multiplier (PSM) is defined as the ratio of the fault current in secondary Amps to the relay plug setting.
- For phase relays the pick-up setting is determined by allowing a margin for overload above the nominal current, as in the following expression

$$\text{Pick-up setting} = (\text{OLF} \times \mathbf{I_{nom}}) / \text{CTR}$$

where,

OLF = Overload factor that depends on the element being protected.

I_{nom} = Nominal circuit current rating

CTR = CT Ratio

Time dial setting

- The time-dial setting adjusts the time –delay before the relay operates whenever the fault current reaches a value equal to, or greater than the relay setting.
- The time-dial setting is also referred to as time multiplier setting (TMS)

Discrimination by Time

In this method an appropriate time interval is given by each of the relays controlling the CBs in a power system to ensure that the breaker nearest the fault opens first.

A simple radial distribution system is considered to illustrate this principle

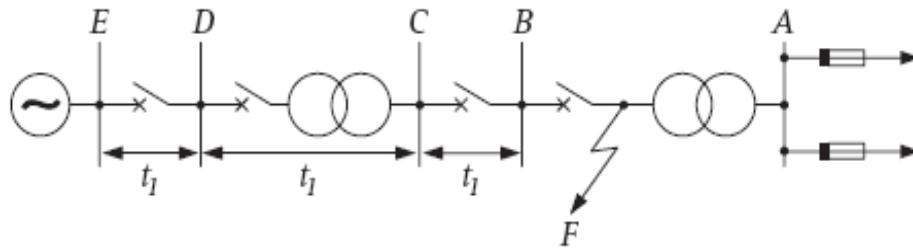

Fig. 2.6 A radial distribution system with time-discrimination

- The main disadvantage of this method of discrimination is that the longest fault clearance time occurs for faults in the section closest to the power source, where the fault level is highest.

Discrimination by Current

- Discrimination by current relies on the fact that the fault current varies with the position of the fault , because of the difference in impedance values between the source and the fault .
- The relays controlling CBs are set to operate at suitably tapered values such that only the relay nearest the fault trips its circuit breaker.

Inverse time over current relay characteristic is evolved to overcome the limitations imposed by the independent use of either time or over current coordination.

Directional over-current Relays

1. When fault current can flow in both directions through the relay location, it is necessary to make the response of the relay directional by introduction of directional control elements.
2. These are basically power measuring devices in which the system voltage is used as a reference for establishing the relative phase of the fault current.

Basically, an AC directional relay can recognize certain difference in phase angle between two quantities, just as a D.C. directional relay recognize difference in polarity

The Polarizing Quantity of a Directional Relay

1. It is the reference against which the phase angle of the other quantity is compared. Consequently the phase angle of the polarizing quantity must remain fixed when other quantity suffers wide change in phase angle.
2. The voltage is chosen as the “polarizing” quantity in the current-voltage induction type directional relay.
3. Four pole induction cup constructions is normally used.

Distance relay

Distance relay is used for the protection of transmission line

In a distance relay, instead of comparing the local line current with the current at far end of line, the relay compares the local current with the local voltage in the corresponding phase or suitable components of them

Principle of Operation of Distance Relay

1. The basic principle of measurement involves the comparison of fault current seen by the relay with the voltage at relaying point; by comparing these two quantities.
2. It is possible to determine whether the impedance of the line up to the point of fault is greater than or less than the predetermined reach point impedance

There are two types of torques

1. Restraining torque

$$T_r \propto V_F^2$$

2. Operating torque

$$T_o \propto I_F^2$$

The relay trips when T_0 greater than T_r

$$KI_F^2 > V_F^2$$

The constant K depends on the design of the electromagnets.

Types of Distance Relay

Distance relays are classified depending on their operating characteristic in the R-X plane

- Impedance Relay
- Mho Relay
- Reactance Relay

Disadvantage of Impedance Relay

1. It is not directional.
2. It is affected by the Arc resistance
3. It is highly sensitive to oscillations on the power system, due to large area covered by its circular characteristic

Operating Characteristic of Mho Relay

The Mho relay combines the properties of impedance and directional relays. Its characteristic is inherently directional and the relay only operates for faults in front of the relay location.

Operating Characteristic of Reactance Relay

1. The reactance relay is designed to measure only reactive component of the line reactance.
2. The fault resistance has no affect on the reactance relay

Differential Relay

- The most positive method of protecting a circuit is to arrange relays to compare the currents entering and leaving it, which should be the same under normal conditions and during an external fault. Any difference current must be flowing in to a fault within the protected circuit

Differential Protection current balance

- When this system is applied to electrical equipment (Generator stator windings, Transformer, Bus bars etc.) it is called differential current protection.
- When it is applied to lines and cables it is called pilot differential protection because pilot wires or an equivalent link or channel is required to bring the current to the relay from the remote end of the line.

The CTs at both ends of the protected circuit connected so that for through load or through fault conditions current circulates between the interconnected CTs. The over-current relay is normally connected across equipotential points and therefore doesn't operate.

- Circulating current balance methods are widely used for apparatus protection where CTs are within the same substation area and interconnecting leads between CTs are short (e.g. generator stator windings, Transformer, Bus bars etc.)
- The circulating current balance method is also called longitudinal differential protection or Merz-Price differential protection system.
- The current in the differential relay would be proportional to the phasor difference between the currents that enter and leave the protected circuit. If the current through the relay exceeds the pick-up value, then the relay will operate.

Static Relays

Advantages of Static Relays

- Due to the amplification of energizing signals obtainable, the sources need only provide low power. Therefore the size of the associated current and voltage transformers could be reduced.
- Improved accuracy and selectivity.
- Fast operation of relays and hence fast clearance of faults.
- Flexibility of circuitry would allow new and improved characteristics.
- The relays would be unaffected by the number of operations.

Basic Circuits Employed

- Timers
- Phase comparators
- Level detectors
- Integrators

- Polarity detectors

High reliability operational amplifiers are used for realizing the basic components of static relays

Numerical Protection

Numerical relays are technically superior to the conventional type relays. Their general characteristics are:

- Reliability
- Self diagnosis
- Event and disturbance records
- Adaptive Protection
- Integration of Digital Systems

Typical Architecture of Numerical Relays

Numerical relays are made up from modules with well defined functions.

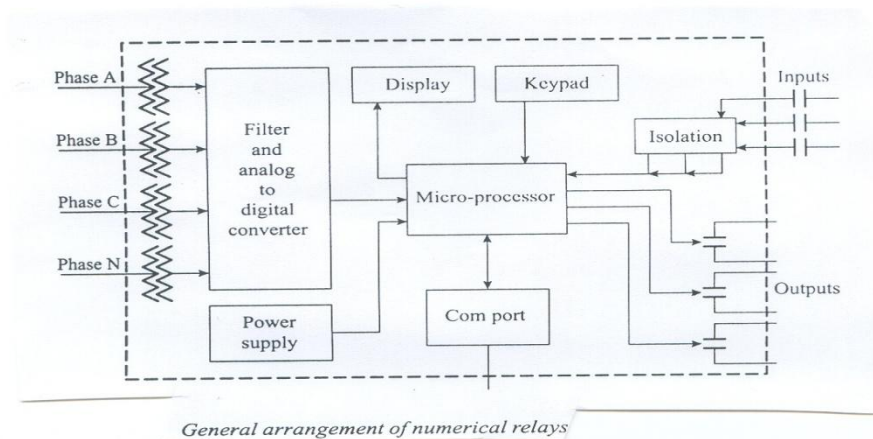

Fig. 2.7 Numerical Relay Architecture

Digital Relay Logic

- The digital relay does not record the analog signal, but only samples of the signal, which are spread in time.

- the mathematics of discrete signal processing is used.
- The relay is programmed to apply various forms of digital signal processing algorithms to the observed samples and based on the results of these computations, the decision to trip is made.

Protection of Feeders

Media used for Protection Signaling

- Power - line - carrier circuits
- Pilot Wires

Power Line Carrier

- The signal propagation medium is power line itself, communication between ends of the power line being effected by means of a superimposed carrier, carrier frequency signal carried by the power circuit conductors.
- The band of frequencies employed for the carrier frequency signal is 70-700khz.
- 2. Power level is 1-2 w for continuous signaling.
- 3. 10-20 w for short -time signaling

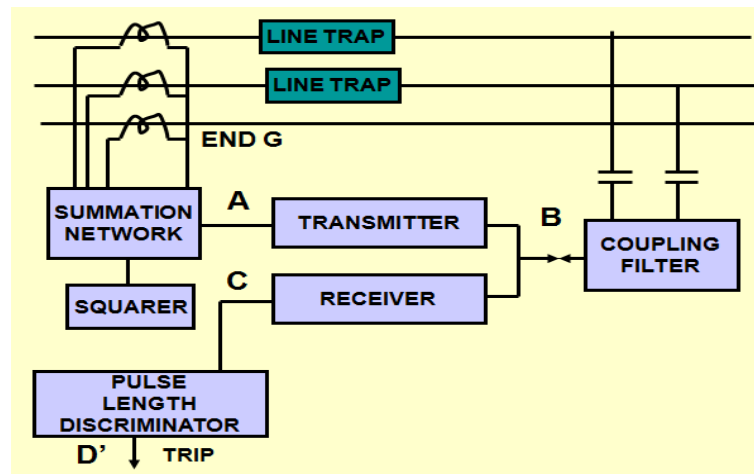

Fig. 2.8 Over-current Protection and Earth Faults

Generator Protection

- The range of size of generators extends from a few hundred KVA to more than 500MVA

- Small and Medium sized sets may be directly connected to the distribution system

A larger unit is usually associated with an individual transformer, through which the set is coupled to the EHV transmission system. No switchgear is provided between the generator and transformer, which are treated as a unit. The neutral point of the generator is usually earthed, so as to facilitate the protection of the stator winding and associated system

- Impedance is inserted in the earthing lead to limit the magnitude of the earth fault current.
- Severe arcing to the machine core burns the iron at the point of fault and welds the laminations together. The welding of laminations would most likely result in local overheating.
- In case of severe damage to the core, it may require rebuilding of the core, which would involve expensive rebuilding of the windings
- Practice as to the degree of fault current limitation varies from approximately rated current on one hand to comparatively low values on the other
- Sometimes, it is asserted that if fault current is limited to 5A, burning of the core will not occur readily.
- Generators which are directly connected to the transmission or distribution system are usually earthed through a resistance which will pass approximately rated current to a terminal earth fault
- In case of generator-transformer unit, the generator winding and primary winding of a transformer can be treated as an isolated system which is not influenced by the earthing requirements of the transmission system
- Modern practice is to use a large earthing transformer (5-100 KVA) – the secondary winding which is designed for 100-500V is loaded with a resistor of a value, which when referred through the transformer ratio, will pass a suitable fault current the resistor is therefore of low value and can be of rugged construction
- The equivalent resistance in the stator circuit should not exceed the impedance as system frequency of the total summated capacitance of the three phases
- The resistance component of the fault current should not be less than the residual capacitance current, that is $3 I_{c0}$

Transformer Protection

- The power transformer is one of the most important links in a power transmission and distribution system.
- It is a highly reliable piece of equipment. This reliability depends on
 - adequate design
 - careful erection
 - proper maintenance
 - Application of protection system.

Protection Equipment Includes

1. Surge diverters
2. Gas relay: It gives early warning of a slowly developing fault, permitting shutdown and repair before severe damage can occur.
3. Electrical relays.
 - The choice of suitable protection is also governed by economic considerations. Although this factor is not unique to power transformers, it is brought in prominence by the wide range of transformer ratings used(few KVA to several hundred MVA)
 - Only the simplest protection such as fuses can be justified for transformers of lower ratings.
 - For large transformers best protection should be provided.

Types of Faults Affecting Power Transformer

- Through Faults
 - a) Overload conditions.
 - b) External short-circuit conditions.

The transformer must be disconnected when such faults occur only after allowing a predetermined time during which other protective gears should have operated.

- Internal Faults
The primary protection of a power transformer is intended for a condition which arises as a result of faults inside the protection zone.

1. Phase-to-earth fault or phase-to-phase fault on HV and LV external terminals
2. Phase-to-earth fault or phase-to-phase fault on HV and LV windings.
3. Interturn faults of HV and LV windings.
4. Earth fault on tertiary winding or short circuit between turns of a tertiary windings.

Nature & Effect of Transformer Faults

A faults on transformer winding is controlled in magnitude by

- a) Source & neutral earthing impedance
- b) Leakage reactance of the transformer
- c) Position of the fault on the winding.

Bus Zone Protection

The protection scheme for a power system should cover the whole system against all probable types of fault.

Unrestricted forms of line protection such as over current and distance systems, meet this requirement, although faults in the Bus bar zone are cleared only after some time delay.

If unit protection is applied to feeder and plant the bus bars are not inherently protected.

Bus bars have been left without specific protection for one or more of the following reasons:

- The bus bars and switchgear have high degree of reliability, to the point of being regarded as intrinsically safe.

Bus-bar Faults

- Majority of bus faults involve one phase and earth, but faults arise from many causes and a significant number are inter-phase clear of earth.
- With fully phase-segregated metal clad gear, only earth faults are possible, and a protective scheme need have earth fault sensitivity only.
- For outdoor bus-bars , protection schemes ability to respond to inter-phase faults clear of earth is an advantage

Types of Protection Schemes

- System protection used to cover bus bars
- Frame –earth protection
- Differential protection

System Protection

- A system protection that includes over current or distance systems will inherently give protection cover to the bus bars.
- *Over current protection* will only be applied to relatively simple distribution systems, or as a back-up protection set to give considerable time delay. *Distance protection* will provide cover with its second zone.
- In both cases, therefore ,the bus bar protection so obtained is slow

Frame-Earth Protection

- This is purely an earth fault system, and, in principle, involves simply measuring the fault current flowing from the switchgear frame to earth. To this end a current transformer is mounted on the earthing conductor and is used to energize a simple instantaneous relay.

MODULE-IV

Stability of power system is its ability to return to normal or stable operating condition after been subjected to some of disturbance. Instability means a condition representing loss of synchronism or fall out of step.

The instability of power system is divided into two parts

1. Steady state stability
2. Transient stability

Increase in load is a kind of disturbance to power system. If the increase in load takes place gradually and slowly in small steps and the system withstand this change in load and operates satisfactorily then this system phenomena is said to be STEADY STATE STABILITY.

Cause of transient disturbances

1. Sudden change of load.
2. Switching operation.
3. Loss of generation.
4. Fault.

Due to the following sudden disturbances in the power system, rotor angular difference, rotor speed and power transfer undergo fast changes whose magnitude are dependent upon the severity of disturbances.

If the disturbance is so large that the angular difference increases so much which can cause the machine out of synchronism. This kind of instability is denoted as transient instability. It is a very fast phenomenon it occurs within one second for the generating unit closer to the disturbance.

Dynamics Of A Synchronous Machine

The kinetic energy of the rotor at synchronous machine is

$$KE = \frac{1}{2} J \omega_{sm}^2 \times 10^{-6} MJ \quad (4.1)$$

J =rotor moment of inertia in kg-m²

ω_{sm} =synchronous speed in rad (mech)/s

$\omega_s = \left(\frac{P}{2}\right) \omega_{sm}$ =rotor speed in rad(elect/s)

P =number of machine poles

$$KE = \frac{1}{2} \left(J \left(\frac{2}{P} \right)^2 \omega_s \times 10^{-6} \right) \omega_s = \frac{1}{2} M \omega_s \quad (4.2)$$

Where

$$M = J \left(\frac{2}{P} \right)^2 \omega_s \times 10^{-6} = \text{Moment of inertia MJ-s/elect. rad}$$

now inertia constant h be written as

$$GH = KE = \frac{1}{2} M \omega_s \quad \text{mj} \quad (4.3)$$

g = machine rating(base)in mva(3-phase)

h =inertia constant in mj/mva or mw-s/mva

so,

$$M = \frac{2GH}{\omega_s} = \frac{GH}{\pi f} \text{MJ-s/elect.rad} \quad (4.4)$$

$$= \frac{GH}{180f} \text{MJ-s/elect.rad} \quad (4.5)$$

Taking G as base, the inertia constant in pu is

$$M = \frac{H}{\pi f} \text{ s}^2/\text{elect.rad} \quad (4.6)$$

$$M = \frac{H}{180f} \text{ s}^2/\text{elect.degree} \quad (4.7)$$

Swing Equation

The differential equation that relates the angular momentum M , acceleration power P_a and the rotor angle δ is known as swing equation. Solution of swing equation shows how the rotor angle changes with respect time following a disturbance. The plot δ Vs t is known as swing curve. The differential equation governing the rotor dynamics can then be written as.

$$J \frac{d^2 \theta_m}{dt^2} = T_m - T_e \quad (4.8)$$

where,

J = rotor moment of inertia in kg-m², θ_m = angle in radian (mech.)

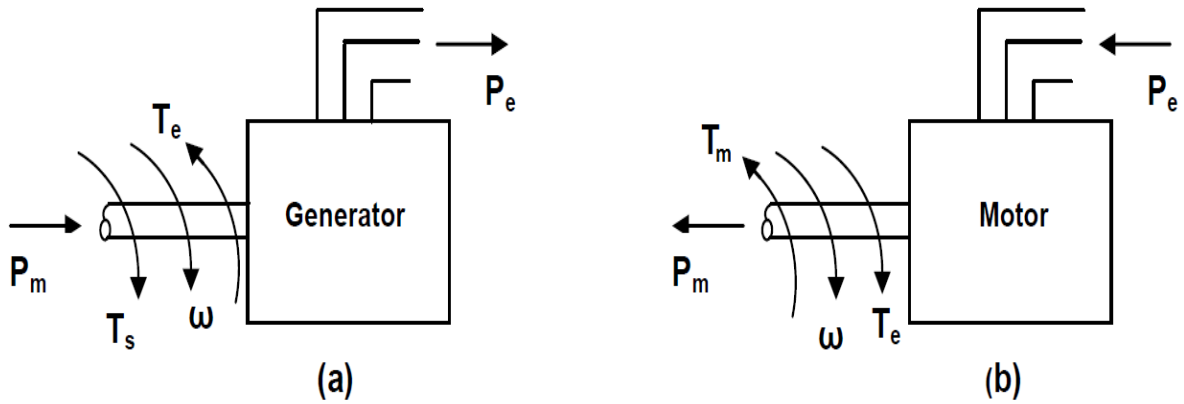

Fig. 4.1 Electrical and mechanical power flow in motor

While the rotor undergoes dynamics as per Equation (9), the rotor speed changes by insignificant magnitude for the time period of interest (1s)

Equation (4.8) can therefore be converted into its more convenient power form by assuming the rotor speed (ω_{sm}). Multiplying both sides of Equation (4.8) by ω_{sm} we can write

$$J\omega_{sm} \frac{d^2\theta_m}{dt^2} \times 10^{-6} = P_m - P_e \text{ MW} \quad (4.9)$$

Where,

P_m = mechanical power input in MW

P_e = electrical power output in MW; stator copper loss is assumed neglected.

Rewriting Equation (4.9)

$$\left(J \left(\frac{2}{P} \right)^2 \omega_s \times 10^{-6} \right) \frac{d^2\theta_e}{dt^2} = (P_m - P_e) \text{ MW} \quad (4.11)$$

$$M \frac{d^2\theta_e}{dt^2} = P_m - P_e \text{ MW} \quad (4.12)$$

Where

θ_e = angle in rad.(elect.)

As it is more convenient to measure the angular position of the rotor with respect to a synchronously rotating frame of reference.

Let us assume,

$$\delta = \theta_e - \omega_s t \quad (4.13)$$

δ is rotor angular displacement from synchronously rotating reference frame, called **Torque Angle/Power Angle**.

From Equation (4.9)

$$\frac{d^2 \theta_e}{dt^2} = \frac{d^2 \delta}{dt^2} \quad (4.14)$$

Hence Equation (4.11) can be written in terms of δ as

$$M \frac{d^2 \delta}{dt^2} = P_m - P_e MW \quad (4.15)$$

Using Equation (4.11) we can also write

$$\left(\frac{GH}{\pi f} \right) \frac{d^2 \delta}{dt^2} = P_m - P_e MW \quad (4.16)$$

Dividing through by G , the MVA rating of the machine

$$M(pu) \frac{d^2 \delta}{dt^2} = P_m - P_e \quad (4.17)$$

Where

$$M(pu) = \frac{H}{\pi f}, \quad \frac{H}{\pi f} \frac{d^2 \delta}{dt^2} = P_m - P_e \quad \text{pu}$$

Equation (4.17) is called as swing equation and it describes the rotor dynamics for a synchronous machine (generating/motoring). It is a second-order differential equation where the damping term (proportional to $d\delta/dt$) is absent because of the assumption of a loss less machine and the fact that the torque of damper winding has been ignored. Since the electrical power P_e depends upon the sine of angle δ the swing equation is a non-linear second-order differential equation.

Multi-Machine System

In a multi-machine system a common system base must be chosen

Let

G_{mach} = machine rating (base)

G_{system} = system base

Equation(18) can then be written as

$$\frac{G_{mach}}{G_{system}} \left(\frac{H_{mach}}{f} \frac{d^2 \delta}{dt^2} \right) = (P_m - P_e) \frac{G_{mach}}{G_{system}}$$
$$\text{Or } \frac{H_{system}}{\pi f} \frac{d^2 \delta}{dt^2} = P_m - P_e \text{ pu in system base.} \quad (4.18)$$

Where

$$H_{system} = H_{mach} \left(\frac{G_{mach}}{G_{system}} \right) \quad (4.19)$$

Consider the swing equations of two machines or a common system base.

$$\frac{H_1}{\pi f} \frac{d^2 \delta_1}{dt^2} = P_{m1} - P_{e1} \text{ pu} \quad (4.20)$$

$$\frac{H_2}{\pi f} \frac{d^2 \delta_2}{dt^2} = P_{m2} - P_{e2} \text{ pu} \quad (4.21)$$

Since the machine rotors swings together (coherently or in unison)

$$\delta_1 = \delta_2 = \delta$$

Adding Equation (4.20) and (4.21)

$$\frac{H_{eq}}{\pi f} \frac{d^2 \delta}{dt^2} = P_m - P_e \quad (4.22)$$

Where

$$P_m = P_{m1} + P_{m2}$$

$$P_e = P_{e1} + P_{e2}$$

$$H_{eq} = H_1 + H_2$$

The two machines swinging coherently are thus reduced to a single machine as in Equation (4.22), the equivalent inertia in (4.22) can be written as

$$H_{eq} = H_{1mach} \frac{G_{1mach}}{G_{system}} + H_{2mach} \frac{G_{2mach}}{G_{system}} \quad (4.23)$$

The above results are easily extendable to any number of machines swinging coherently. To solving the swing equation (Equation (4.23), certain simplifying assumptions are usually made. These are:

1. Mechanical power input to the machine (P_m) remains constant during the period of electromechanical transient of interest. In other words, it means that the effect of the turbine governing loop is ignored being much slower than the speed of the transient. This assumption leads to pessimistic result-governing loop helps to stabilize the system.
2. Rotor speed changes are insignificant-these have already been ignored in formulating the swing equation.
3. Effect of voltage regulating loop during the transient is ignored, as a consequence the generated machine emf remains constant. This assumption also leads to pessimistic results-voltage regulator helps to stabilize the system.

Before the swing equation can be solved, it is necessary to determine the dependence of the electrical power output (P_e) upon the rotor angle.

Simplified Machine Model

For a non-salient pole machine, the per-phase induced emf-terminal voltage equation under steady conditions is.

$$E = V + jX_d I_d + jX_q I_q; X_d > X_q \quad (4.24)$$

Where

$$I = I_d + I_q$$

Under transient condition

$$X_d \rightarrow X_d' < X_d$$

$X'_q = X_d$ Since the main field is on the d-axis

$X'_d < X_q$;

Equation (4.24) during the transient modifies to.

$$\begin{aligned} E' &= V + jX'_d I_d + jX_q I_q \\ &= V + jX_q (I - I_d) + jX'_d I_d \end{aligned} \quad (4.25)$$

$$= (V + jX_d I) + j(X'_d - X_q) I_d \quad (4.26)$$

The phasor diagram corresponding to Equation (4.25) and (4.26) is drawn in Fig. 4.2. Since under transient condition, $X'_d < X_d$ but X_d remains almost unaffected, it is fairly valid to assume that

$X'_d \approx X_d$

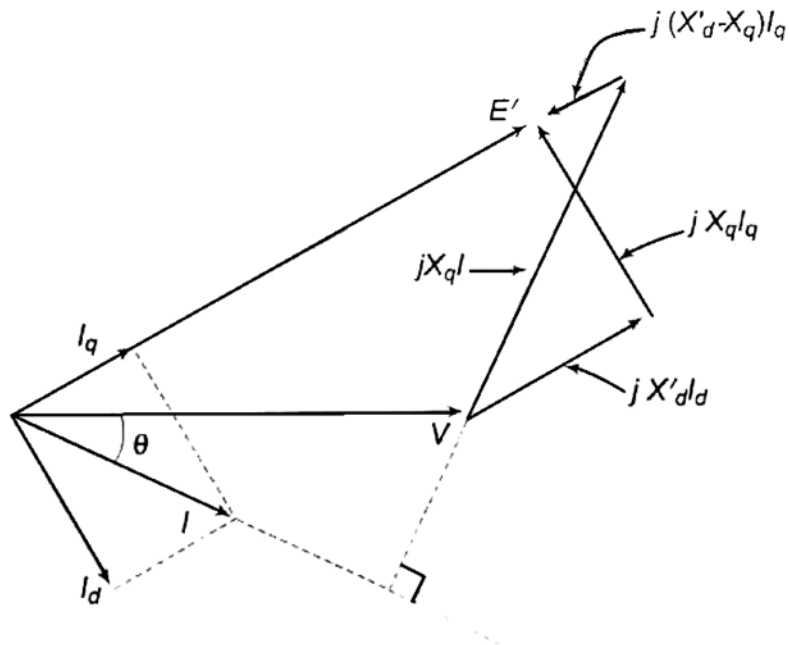

Fig. 4.2 Phasor diagram of a salient pole machine

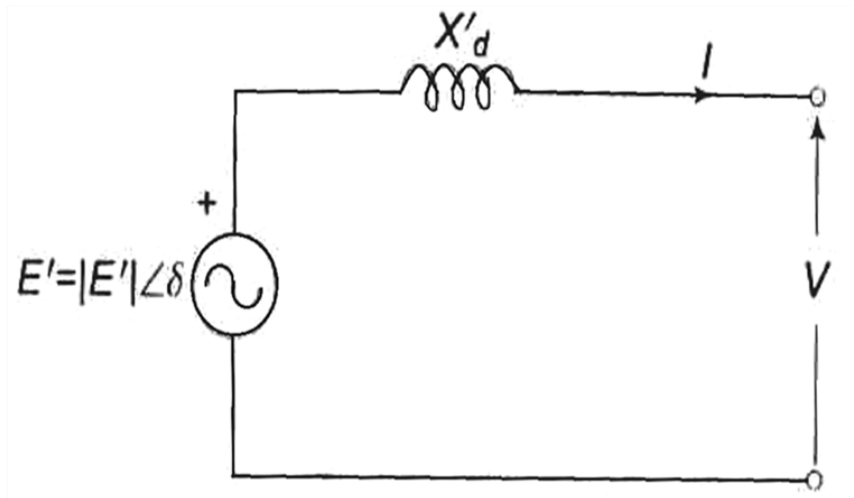

Fig.4.3 Simplified machine model.

The machine model corresponding to Eq. (4.26) is drawn in Fig. (4.3) which also applies to a cylindrical rotor machine where $X'_d = X'_q = X'_s$ (transient synchronous reactance).

Power Angle Curve

For the purposes of stability studies $|E'|$, transient emf of generator motor remains constant or is the independent variable determined by the voltage regulating loop but V , the generator determined terminal voltage is a dependent variable. Therefore, the nodes (buses) of the stability study network to the emf terminal in the machine model as shown in Fig.4.4, while the machine reactance (X'_d) is absorbed in the system network as different from a load flow study. Further, the loads (other than large synchronous motor) will be replaced by equivalent static admittances (connected in shunt between transmission network buses and the reference bus).

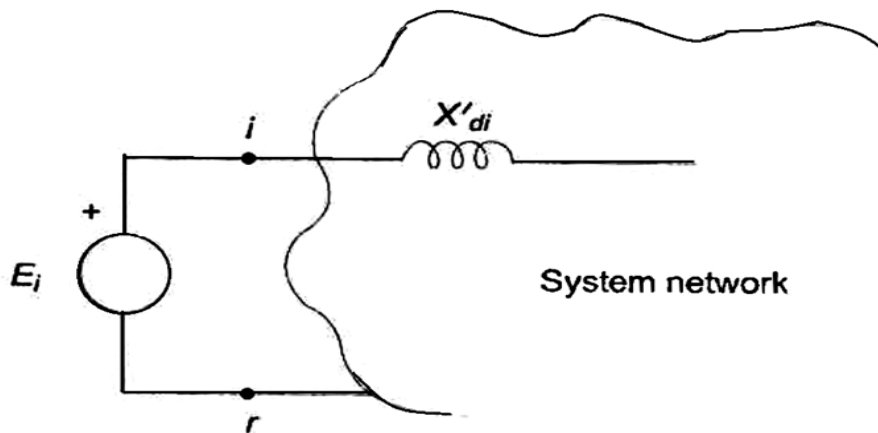

Fig. 4.4 Simplified Machine studied Network

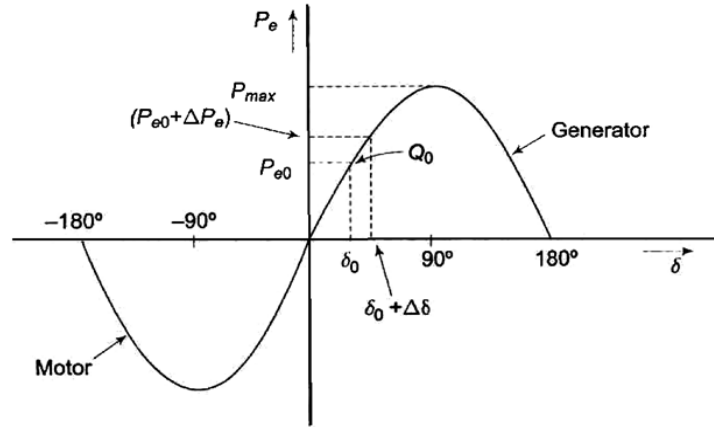

Fig 4.5 Power Angle Curve

This is so because load voltages vary during a stability study (in a load flow study, these remain constant within a narrow band). The simplified power angle equation is

$$P_e = P_{\max} \sin \delta \quad (4.27)$$

Where

$$P_{\max} = \frac{|E'_1||E'_2|}{X} \quad (4.28)$$

The graphical representation of power angle equation (4.28) is shown in Fig. 4.5. The swing equation (4.27) can now be written as

$$\frac{H}{\pi f} \frac{d^2 \delta}{dt^2} = P_m - P_e \text{ pu} \quad (4.29)$$

It is a non linear second-order differential equation with no damping.

Machine Connected to Infinite Bus

Figure 4.6 is the circuit model of a single machine connected to infinite bus through a line of reactance X_e . In this simple case

$$X'_{transfer} = X'_d + X_e$$

From Eq (4.30) we get

$$P_e = \frac{|E' || V|}{X_{transfer}} \sin \delta = P_{\max} \sin \delta \quad (4.30)$$

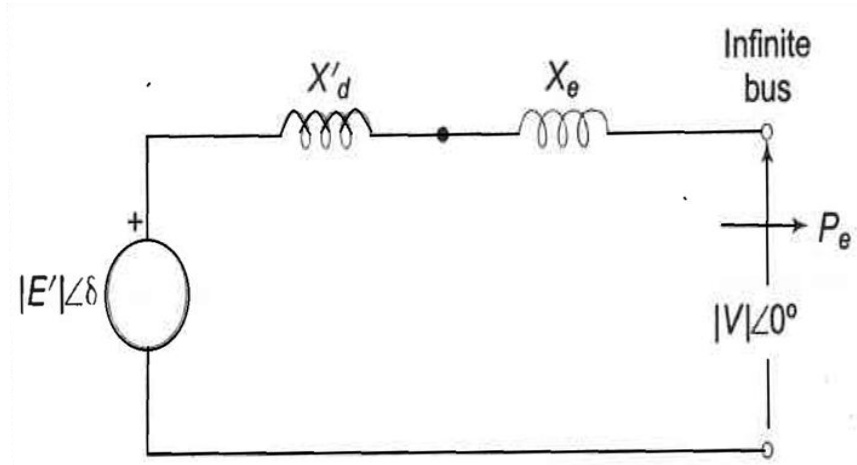

Fig. 4.6 Machine connected to infinite bus bar

The dynamics of this system are described in Eq. (4.15) as

$$\frac{H}{\pi f} \frac{d^2 \delta}{dt^2} = P_m - P_e \text{ pu} \quad (4.31)$$

Two Machine Systems

The case of two finite machines connected through a line (X_e) is illustrated in Fig. 5 where one of the machines must be generating and the other must be motoring. Under steady condition, before the system goes into dynamics and the mechanical input/output of the two machines is assumed to remain constant at these values throughout the dynamics (governor action assumed slow). During steady state or in dynamic condition, the electrical power output of the generator must be absorbed by the motor (network being lossless).

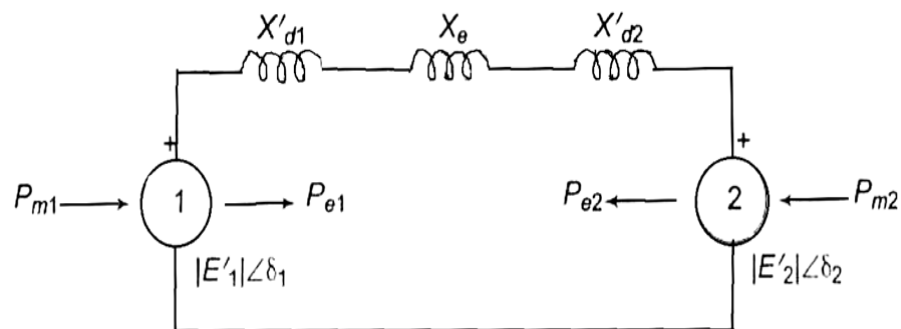

Fig. 4.7 Two machine system

Thus at all time

$$P_{m1} = -P_{m2} = P_m \quad (4.32)$$

$$P_{e1} = -P_{e2} = P_e \quad (4.33)$$

The swing equations for the two machines can now be written as

$$\frac{d^2\delta_1}{dt^2} = \pi f \left(\frac{P_{m1} - P_{e1}}{H_1} \right) = \pi f \left(\frac{P_m - P_e}{H_1} \right) \quad (4.34)$$

$$\text{And } \frac{d^2\delta_2}{dt^2} = \pi f \left(\frac{P_{m2} - P_{e2}}{H_1} \right) = \pi f \left(\frac{P_e - P_m}{H_1} \right) \quad (4.35)$$

Subtracting Eq. (36) from Eq. (35)

$$\frac{d^2(\delta_1 - \delta_2)}{dt^2} = \pi f \left(\frac{H_1 + H_2}{H_1 H_2} \right) (P_m - P_e) \quad (4.36)$$

$$\text{Or } \frac{H_{eq}}{\pi f} \frac{d^2\delta}{dt^2} = P_m - P_e \quad (4.37)$$

Where $\delta = \delta_1 - \delta_2$

$$H_{eq} = \left(\frac{H_1 H_2}{H_1 + H_2} \right) \quad (4.38)$$

The electrical power interchange is given by expression.

$$P_e = \frac{|E'_1| |E'_2|}{X'_{d1} + X_e + X'_{d2}} \sin \delta \quad (4.39)$$

The swing equation Eq. (4.35) and the power angle equation Eq. (4.39) have the same form as for a single machine connected to infinite bus. Thus a two-machine system is equivalent to a

single machine connected to infinite bus. Because of this, the single-machine (connected to infinite bus) system would be studied here.

Steady State Stability

The steady state stability limit of a particular circuit of a power system is defined as the maximum power that can be transmitted to the receiving end without loss of synchronism.

Consider the simple system of Fig. 4.7 whose dynamics is described by equations

$$M \frac{d^2 \delta_e}{dt^2} = P_m - P_e \quad (4.40)$$

$$M = \frac{H}{\pi f} \text{ in pu system} \quad (4.41)$$

And,

$$P_e = \frac{|E||V|}{X_d} \sin \delta = P_{\max} \sin \delta \quad (4.42)$$

For determination of steady state stability, the direct axis reactance (X_d) and, voltage behind X_d are used in the above equations. Let the system be operating with steady power transfer of $P_{e0}=P_m$ with torque angle δ_0 as indicated in the figure. Assume a small increment ΔP in the electric power with the input from the prime mover remaining fixed at P_m (governor response is slow compared to the speed of energy dynamics), causing the torque angle to change to $(\delta_0 + \Delta\delta)$. Linearizing about the operating point $Q_0(P_{e0}, \delta_0)$ we can written as.

$$\Delta P_e = \left(\frac{\partial P_e}{\partial \delta} \right)_0 \Delta \delta$$

The excursions of $\Delta\delta$ are then described by

$$M \frac{d^2 \Delta \delta}{dt^2} = P_m - (P_{e0} + \Delta P_e) = -\Delta P_e$$

or

$$M \frac{d^2 \Delta \delta}{dt^2} + \left[\frac{\partial P_e}{\partial \delta} \right]_0 \Delta \delta = 0 \quad (4.43)$$

or

$$Mp^2 + \left(\frac{\partial P_e}{\partial \delta} \right)_0 \Delta \delta = 0$$

Where

$$p = \frac{d}{dt}$$

The system stability to small change is determined from the characteristic equation.

$$Mp^2 + \left[\frac{\partial p_e}{\partial \delta} \right]_0 = 0$$

Its two roots are

$$p = \pm \left[- \frac{\partial p_e / \partial \delta}{M} \right]^{\frac{1}{2}}$$

As long as $(\partial p_e / \partial \delta)_0$ is positive, the roots are purely imaginary and conjugate and the system behaviour is oscillatory about δ_0 . Line resistance and damper windings of machine, which have been ignored in the above modelling, cause the system oscillations to decay. The system is therefore stable for a small increment in power so long as

$$\left(\frac{\partial p_e}{\partial \delta} \right)_0 > 0 \quad (4.44)$$

When $(\partial p_e / \partial \delta)_0$ is negative, the roots are real, one positive and the other negative but of equal magnitude. The torque angle therefore increases without bound upon occurrence of a small power increment (disturbance) and the synchronism is soon lost. The system is therefore unstable for

$$\left(\frac{\partial p_e}{\partial \delta}\right)_0 < 0 \quad (4.45)$$

$(\partial p_e / \partial \delta)_0$ is known as synchronizing coefficient. This is also called stiffness (electrical) of synchronous machine.

Assuming $|E|$ and $|V|$ to remain constant, the system is unstable, if

$$\frac{|E||V|}{X} \cos \delta_0 < 0$$

$$\delta_0 > 90^\circ \quad (4.46)$$

The maximum power that can be transmitted without loss of stability (steady state) occurs for

$$\delta_0 = 90^\circ \quad (4.47)$$

$$P_{\max} = \frac{|E||V|}{X} \quad (4.48)$$

If the system is operating below the limit of steady stability condition (Eq.4.48), it may continue to oscillate for a long time if the damping is low. Persistent oscillations are a threat to system security. The study of system damping is the study of dynamical stability.

The above procedure is also applicable for complex systems wherein governor action and excitation control are also accounted for. The describing differential equation is linearized about the operating point. Condition for steady state stability is then determined from the corresponding characteristic equation (which now is of order higher than two).

It was assumed in the above account that the internal machine voltage $|E|$ remains constant (i.e., excitation is held constant). The result is that as loading increases, the terminal voltage $|V_t|$ dips heavily which cannot be tolerated in practice. Therefore, we must consider the steady state stability limit by assuming that excitation is adjusted for every load increase to keep $|V_t|$ constant. This is how the system will be operated practically. It may be understood that we are still not considering the effect of automatic excitation control.

Some Comment on Steady State Stability

Knowledge of steady state stability limit is important for various reasons. A system can be operated above its transient stability limit but not above its steady state limit. Now, with increased fault clearing speeds, it is possible to make the transient limit closely approach the steady state limit.

As is clear from Eq. (4.50), the methods of improving steady state stability limit of a system are to reduce X and increase either or both $|E|$ and $|V|$. If the transmission lines are of sufficiently high reactance, the stability limit can be raised by using two parallel lines which incidentally also increases the reliability of the system. Series capacitors are sometimes employed in lines to get better voltage regulation and to raise the stability limit by decreasing the line reactance. Higher excitation voltages and quick excitation system are also employed to improve the stability limit.

Transient Stability

The dynamics of a single synchronous machine connected to infinite bus bars is governed by the nonlinear differential equation

$$M \frac{d^2 \delta}{dt^2} = P_m - P_e$$

where

$$P_e = P_{\max} \sin \delta \tag{4.49}$$

or

$$M \frac{d^2 \delta}{dt^2} = P_m - P_{\max} \sin \delta$$

As said earlier, this equation is known as the swing equation. No closed form solution exists for swing equation except for the simple case $P_m = 0$ (not a practical case) which involves elliptical integrals. For small disturbance (say, gradual loading), the equation can be linearised leading to the concept of steady state stability where a unique criterion of stability ($\partial p_e / \partial \delta > 0$) could be established. No generalized criteria are available for determining system stability with large disturbances (called transient stability). The practical approach to the transient stability problem is therefore to list all important severe disturbances along with their possible locations

to which the system is likely to be subjected according to the experience and judgement of the power system analyst. Numerical solution of the swing equation (or equations for a multi-machine case) is then obtained in the presence of such disturbances giving a plot of δ Vs t called the swing curve. If δ starts to decrease after reaching a maximum value, it is normally assumed that the system is stable and the oscillation of δ around the equilibrium point will decay and finally die out. As already pointed out in the introduction, important severe disturbances are a short circuit or a sudden loss of load.

For ease of analysis certain assumptions and simplifications are always made (some of these have already been made in arriving at the swing equation (Eq. 4.49)). All the assumptions are listed, below along with their justification and consequences upon accuracy of results.

1. Transmission line as well as synchronous machine resistance is ignored. This leads to pessimistic result as resistance introduces damping term in the swing equation which helps stability.
2. Damping term contributed by synchronous machine damper windings is ignored. This also leads to pessimistic results for the transient stability limit.
3. Rotor speed is assumed to be synchronous. In fact it varies insignificantly during the course of the stability transient.
4. Mechanical input to machine is assumed to remain constant during the transient, i.e., regulating action of the generator loop is ignored. This leads to pessimistic results.
5. Voltage behind transient reactance is assumed to remain constant, i.e., action of voltage regulating loop is ignored. It also leads to pessimistic results.
6. Shunt capacitances are not difficult to account for in a stability study. Where ignored, no greatly significant error is caused.
7. Loads are modelled as constant admittances. This is a reasonably accurate representation.

Note: Since rotor speed and hence frequency vary insignificantly, the network parameters remain fixed during a stability study.

A digital computer programme to compute the transient following sudden disturbance can be suitably modified to include the effect of governor action and excitation control.

Preset day power system are so large that even after lumping of machines (Eq.(24)), the system remains a multi-machine one. Even then, a simple two machine system greatly aids the

understanding of the transient stability problem. It has been shown in that an equivalent single machine infinite bus system can be found for a two- machine system (Eq. 4.45) to (Eq. 4.49)

Upon occurrence of a severe disturbance, say a short circuit, the power transfer between machines is greatly reduced, causing the machine torque angles to swing relatively. The circuit breakers near the fault disconnect the unhealthy part of the system so that power transfer can be partly restored, improving the chances of the system remain stable. The shorter the time to breaker operating, called *clearing time*, the higher is the probability of the system being stable. Most of the line faults are transient in nature and get cleared on opening the line. Therefore, it is common practice now to employ *auto-reclose breakers* which automatically close rapidly after each of the two sequential openings. If the fault still persists, the circuit breakers open and lock permanently till cleared manually. Since in the majority of faults the first *reclosure* will be successful, the chances of system stability are greatly enhanced by using *autoreclose* breakers.

The procedure of determining the stability of a system upon occurrence of a disturbance followed by various switching off and switching on action called a *stability study*. Steps to be followed in stability study are outlined below for single- machine infinite bus bar system shown in fig. 6. The fault is assumed to be transient one which is cleared by the time of first reclosure. In the case of a permanent fault, this system completely falls apart. This will not be the case in a multi-machine system. The steps listed, in fact, apply to a system of any size.

1. From prefault loading, determine the voltage behind transient reactance and the torque angle δ_0 of the machine with reference to the infinite bus.
2. For the specified fault, determine the power transfer equation $P_e(\delta)$ during fault. In this system $P_e = 0$ for a three-phase fault.
3. From the swing equation starting with δ_0 as obtained in step 1, calculate δ as a function of time using a numerical technique of solving the nonlinear differential equation.
4. After clearance of the fault, once again determine $P_e(\delta)$ and solve further for $\delta(t)$. In this case, $P_e(\delta) = 0$ as when the fault is cleared, the system gets disconnected.
5. After the transmission line is switched on, again find $P_e(\delta)$ and continue to calculate $\delta(t)$.

6. If $\delta(t)$ goes through a maximum value and starts to reduce, the system is regarded as stable. It is unstable if $\delta(t)$ continues to increase. Calculation is increased after a suitable length of time.

Equal Area Criteria for Stability

In a system where one machine is swinging with respect to an infinite bus, it is possible to study transient stability by means of a simple criterion, without resorting to the numerical solution of a swing equation.

Consider the equation

$$M \frac{d^2 \delta}{dt^2} = P_m - P_e = P_a \quad (4.50)$$

P_a =accelerating power

If the system is unstable δ continues to increase indefinitely with time and the machine loses synchronism. On the other hand, if the system is stable, $\delta(t)$ performs oscillations (nonsinusoidal) whose amplitude decreases in actual practice because of damping terms (not included in the swing equation). These two situations are shown in fig. 6. Since the system is non-linear, the nature of its response1 [$\delta(t)$] is not unique and it may exhibit instability in a fashion different from that indicated in Fig. 6, depending upon the nature and severity of disturbance. However, experience indicates that the response $\delta(t)$ in a power system generally falls in the two broad categories as shown in the figure. It can easily be visualized now (this has also been stated earlier) that for a stable system, indication of stability will be given by observation of the first swing where δ will go to a maximum and will start to reduce.

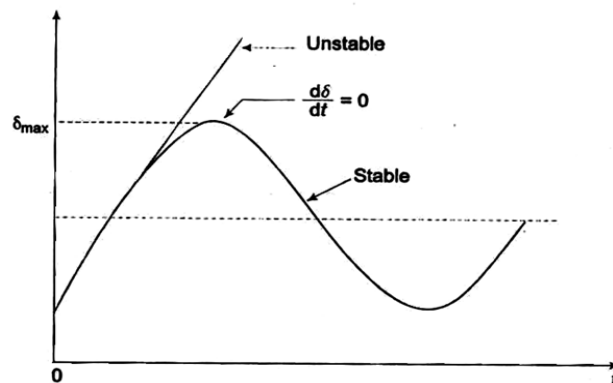

Fig. 4.8 Plot of δ vs t for stable and unstable system.

This fact can be stated as a stability criterion, that the system is stable if at some time

$$\frac{d\delta}{dt} = 0 \quad (4.51)$$

And is unstable, if

$$\frac{d\delta}{dt} > 0 \quad (4.52)$$

The stability criterion for power systems stated above can be converted into a simple and easily applicable form for a single machine infinite bus system. Multiplying both sides of the swing

equation by $\left(2 \frac{d\delta}{dt}\right)$, we get

$$2 \frac{d\delta}{dt} \cdot \frac{d^2\delta}{dt^2} = 2 \frac{P_a}{M} \frac{d\delta}{dt}$$

Integrating, both sides we get

$$\left(\frac{d\delta}{dt}\right)^2 = \frac{2}{M} \int_{\delta_0}^{\delta} P_a d\delta$$

or

$$\frac{d\delta}{dt} = \left(\frac{2}{M} \int_{\delta_0}^{\delta} P_a d\delta\right)^{\frac{1}{2}} \quad (4.53)$$

Where δ_0 is the initial rotor angle and it begins to swing due to disturbances in the system. From Eqs. (4.53) and (4.54), the condition for stability can be written as

$$\left(\frac{2}{M} \int_{\delta_0}^{\delta} P_a d\delta\right)^{\frac{1}{2}} = 0$$

or

$$\int_{\delta_0}^{\delta} P_a d\delta = 0 \quad (4.54)$$

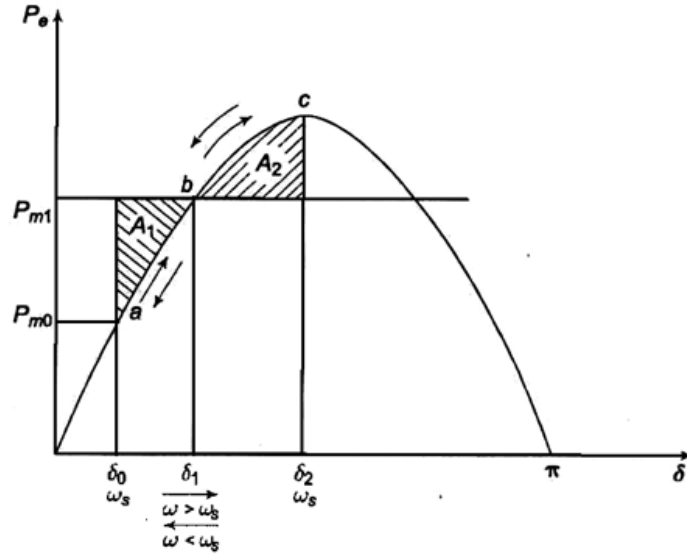

Fig.4.9 $P_e - \delta$ diagram for sudden increase in mechanical input

The condition of stability can therefore be stated as: the system is stable if the area under P_a (accelerating power) - δ curve reduces to zero at some value of δ . In other words, the positive (accelerating) area under $P_a - \delta$ curve must equal the negative (decelerating) area and hence the name 'equal area' criterion of stability. To illustrate the equal area criterion of stability, we now consider several types of disturbances that may occur in a single machine infinite bus bar system. Figure 4.9 shows the transient model of a single machine tied to infinite bus-bar. The electrical power transmitted is given by

$$P_e = \frac{|E'| |V|}{X_d} \sin \delta = P_{\max} \sin \delta$$

Under steady operating condition

$$P_{m0} = P_{e0} = P_{\max} \sin \delta_0$$

This is indicated by the point a in the $P_e - \delta$ diagram of Fig. 4.8.

Let the mechanical input to the rotor be suddenly increased to P_{m1} (by opening the steam valve). The accelerating power $P_a = P_{m1} - P_e$ causes the rotor speed to increase ($\omega > \omega_s$) and so does the rotor angle. At angle δ_1 , $P_a = P_{m1} - P_e = P_{\max} \sin \delta_1 = 0$ (state point at b) but the rotor angle continues to increase as ($\omega > \omega_s$). P_a now becomes negative (decelerating), the rotor speed

begins to reduce but the angle continues to increase till at angle δ_2 , ($\omega > \omega_s$) once again (state point at c). At c), the-decelerating area A_2 equals the accelerating area A_1 , (areas are shaded), i.e.,

$$\int_{\delta_0}^{\delta} P_a d\delta = 0$$

Since the rotor is decelerating, the speed reduces below ω_s and the rotor angle begins to reduce. The state point now traverses the $P_e V_s \delta$ curve in the opposite direction as indicated by arrows in Fig. 8. It is easily seen that the system oscillates about the new steady state point b ($\delta = \delta_1$) with angle excursion up to δ_0 and δ_2 on the two sides. These oscillations are similar to the simple harmonic motion of an inertia-spring system except that these are not sinusoidal.

As the oscillations decay out because of inherent system damping (not modelled), the system settles to the new steady state where

$$P_{m1} = P_e = P_{\max} \sin \delta_1$$

From Fig. 12.20, areas $A_1=A_2$ are given by

$$A_1 = \int_{\delta_0}^{\delta_0} (P_{m1} - P_e) d\delta$$

or

$$A_2 = \int_{\delta_0}^{\delta_2} (P_e - P_{m1}) d\delta$$

For the system to be stable, it should be possible to find angle δ_2 such that $A_1=A_2$. As P_{m1} is increased, a limiting condition is finally reached when A_1 equals the area above the P_{m1} line as shown in Fig 4.10. Under this condition, δ_2 acquires the maximum value such that

$$\delta_2 = \delta_{\max} = \pi - \delta_1 = \pi - \sin^{-1} \frac{P_{m1}}{P_{\max}} \quad (4.55)$$

Any further increase in P_{m1} , means that the area available for A_2 is less than A_1 , so that the excess kinetic energy causes δ to increase beyond point c and the decelerating power changes over to accelerating power, with the system consequently becoming unstable.

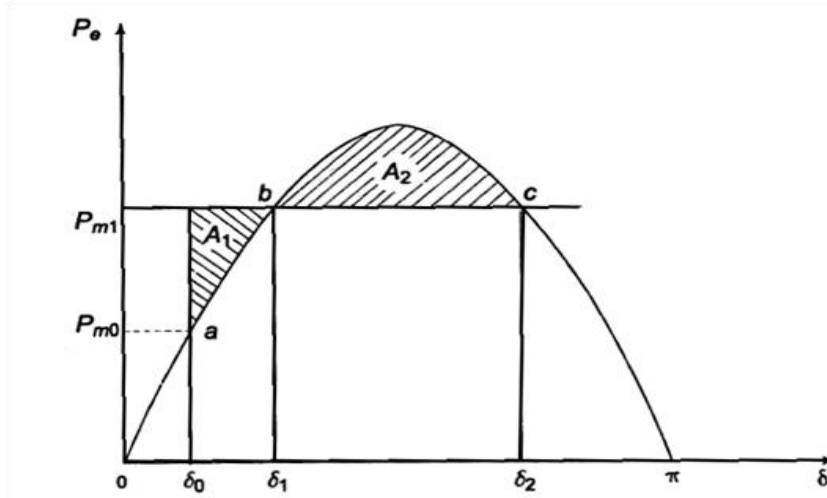

Fig. 4.10 Limiting case of transient stability with mechanical input suddenly increased

It has thus been shown by use of the equal area criterion that there-is an upper limit to sudden increase in mechanical input ($P_{m1} - P_{m0}$), for the system in question to remain stable'

It may be noted from Fig. 9 that the system will remain stable even though the rotor may oscillate beyond $\delta = 90^\circ$, so long as the equal area criteria is met. The condition of $\delta = 90^\circ$ is meant for use in steady state stability only and does not apply to the transient stability case.

Effect of Clearing Time on Stability

Let the system of Fig. 4.9 be operating with mechanical input P_m at a steady angle of δ ($P_m = P_e$) as shown by the point a on the P_e Vs δ diagram of Fig. 4.10. If a 3-phase fault occurs at the point P of the outgoing radial line, the electrical output of the generator instantly reduces to zero, i.e., $P_e = 0$ and the state point drops to b . The acceleration area A_1 begins to increase and so does the rotor angle while the state point moves along bc . At time t_c corresponding to angle δ_c , the faulted line is cleared by the opening of the line circuit breaker. The values of t_c and δ_c are respectively known as *clearing time* and, *clearing angle*. The system once again becomes healthy and transmits $P_e = P_{max} \sin \delta$ i.e. the state point shifts to d on the original P_e Vs δ curve. The rotor now decelerates and the decelerating area A_2 , begins while the state point moves along de . If an angle δ_1 can be found such that $A_2 = A_1$, the system is found to be stable. The system finally settles down to the steady operating point a in an oscillatory manner because of inherent damping.

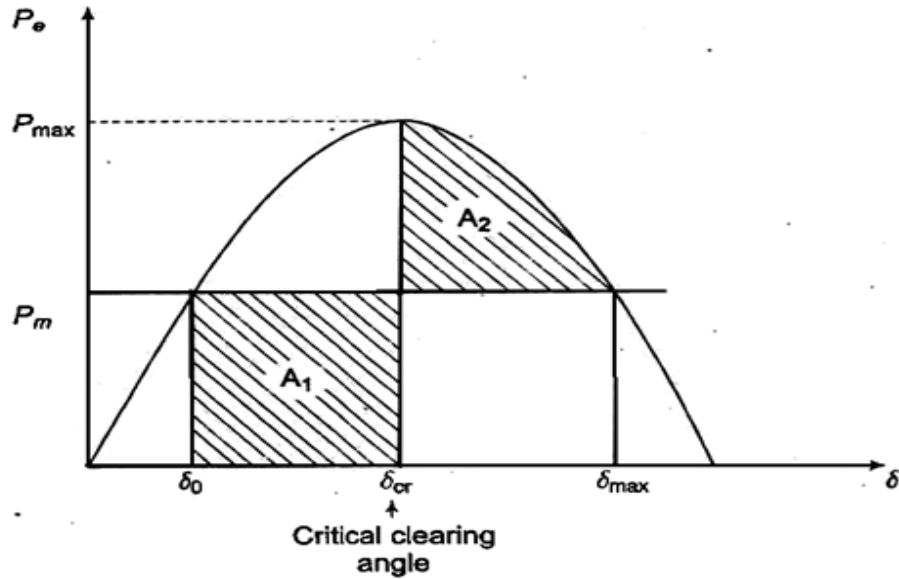

Fig. 4.10 Limiting case of transient stability with critical angle

The value of clearing time corresponding to a clearing angle can be established only by numerical integration except in this simple case. The equal area criterion therefore gives only qualitative answer to system stability as the time when the breaker should be opened is hard to establish.

As the clearing of the faulty line is delayed, A_1 increases and so does δ_1 , to find $A_2=A_1$ till $\delta_1 = \delta_{\max}$ as shown in Fig. 4.10. For a clearing time (or angle) larger than this value, the system would be unstable as $A_2 < A_1$. The maximum allowable value of the clearing time and angle for the system to remain stable are known respectively as *critical clearing time and angle*.

For this simple case ($P_e=0$ during fault), explicit relationships for δ_c (critical) and t_c (critical) are established below. All angles are in radians.

It is easily seen from Fig.4.10

$$\delta_{\max} = \pi - \delta_0 \quad (4.56)$$

and

$$P_m = P_{\max} \sin \delta_0 \quad (4.57)$$

Now

$$A_1 = \int_{\delta_0}^{\delta_{cr}} (P_m - 0) d\delta = P_m (\delta_{cr} - \delta_0)$$

and

$$\begin{aligned} A_2 &= \int_{\delta_{cr}}^{\delta_{max}} (P_{max} \sin \delta - P_m) d\delta \\ &= P_{max} (\cos \delta_{cr} - \cos \delta_{max}) - P_m (\delta_{max} - \delta_{cr}) \end{aligned}$$

For the system to be stable, $A_2 = A_1$ which gives

$$\cos \delta_{cr} = \frac{P_m}{P_{max}} (\delta_{max} - \delta_0) + \cos \delta_{max} \quad (4.58)$$

Where

δ_{cr} =critical clearing angle.

Substituting Eq. (58) and (59) in Eq.(60), we get

$$\delta_{cr} = \cos^{-1} [(\pi - 2\delta_0) \sin \delta_0 - \cos \delta_0] \quad (4.59)$$

During the period the fault is persisting, the swing equation is

$$\frac{d^2 \delta}{dt^2} = \frac{\pi f}{H} P_m; \quad \text{where } P_e = 0 \quad (4.60)$$

Integrating twice

$$\begin{aligned} \delta &= \frac{\pi f}{2H} P_m t^2 + \delta_0 \\ \text{Or } \delta_{cr} &= \frac{\pi f}{2H} P_m t_{cr}^2 + \delta_0 \end{aligned} \quad (4.61)$$

Where

t_{cr} =critical clearing time.

δ_{cr} =critical clearing angle

From Eq. (4.61)

$$\delta_{cr} = \sqrt{\frac{2H(\delta_{cr} - \delta_0)}{\pi \cdot f \cdot P_m}} \quad (4.62)$$

Where δ_{cr} , is given by the expression of Eq. (4.62)

An explicit relationship for determining t_{cr} is possible in this case as during the faulted condition $P_e = 0$ and so the swing equation can be integrated in closed form. This will not be the case in most other situations.

Consider now a single machine tied to infinite bus through two parallel lines as in Fig. 4.11a circuit model of the system is given in Fig. 4.11b.

Let us study the transient stability of the system when one of the lines is suddenly switched off with the system operating at a steady road. Before switching off, power angle curve is given by

$$P_{eI} = \frac{|E'| |V|}{X'_d + X_1 X_2} \sin \delta = P_{\max I} \sin \delta$$

Immediately on switching off line 2, power angle curve is given by

$$P_{eII} = \frac{|E'| |V|}{X'_d + X_1 X_2} \sin \delta = P_{\max II} \sin \delta$$

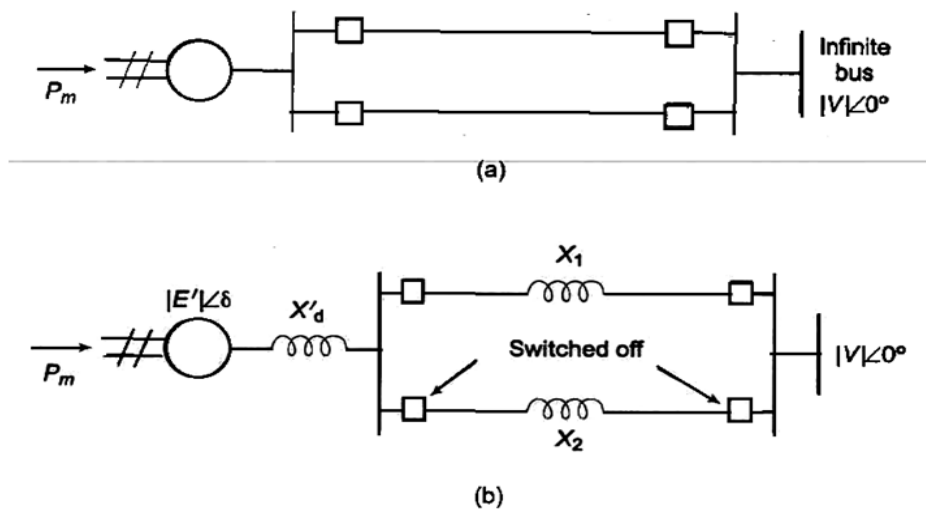

Fig. 4.11 Single machine tied to infinite bus through two parallel lines

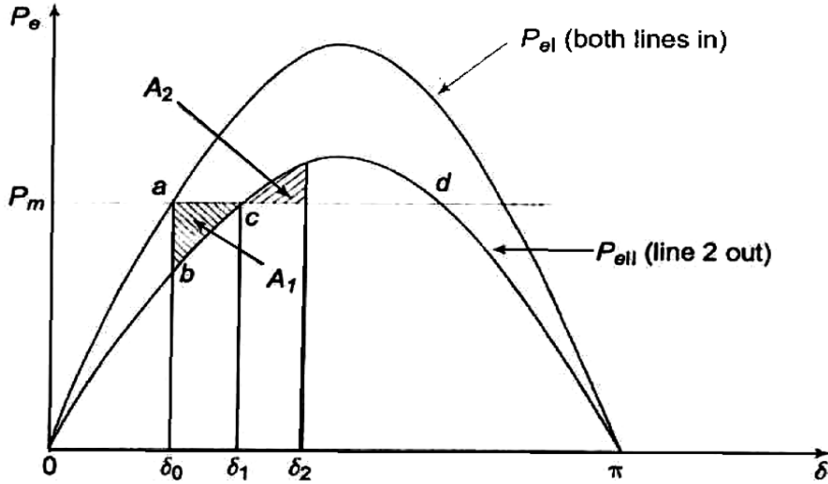

Fig. 4.12 Equal area criterion applied to the opening of one of the two lines in parallel

Both these curves are plotted in Fig. 4.12, wherein $P_{maxII} < P_{maxI}$ as $(X'_d + X_1) > (X'_d + X_1 \parallel X_2)$

The system is operating initially with a steady power transfer $P_e = P_m$ at a torque angle δ_0 on curve I. Immediately on switching off line 2, the electrical operating point shifts to curve II (point b). Accelerating energy corresponding to area A_1 is put into rotor followed by decelerating energy for $\delta_1 > \delta_0$. Assuming that an area A_2 corresponding to decelerating energy (energy out of rotor) can be found such that $A_1 = A_2$, the system will be stable and will finally operate at c corresponding to a new, rotor angle $\delta_1 > \delta_0$. This is so because a single line offers larger reactance and larger rotor angle is needed to transfer the same steady power.

It is also easy to see that if the steady load is increased (line P_m is shifted upward in Fig. 4.12, a limit is finally reached beyond which decelerating area equal to A_1 cannot be found and therefore, the system behaves as an unstable one, For the limiting case of stability, δ_1 has maximum value given by

$$\delta_1 = \delta_{max} = \pi - \delta_c$$

This is the same condition as in the previous example.

We shall assume the fault to be a three-phase one. Before the occurrence of a fault, the power angle curve is given by

$$P_{el} = \frac{|E'| |V|}{X'_d + X_1 X_2} \sin \delta = P_{maxI} \sin \delta$$

This is plotted in fig. 16

Upon occurrence of a three-phase fault at the generator end of line 2 (see Fig. 15a), the generator gets isolated from the power system for purposes of power flow as shown by Fig. 15b. Thus during the period the fault lasts,

$$P_{eII}=0$$

The rotor therefore accelerates and angle δ increases. Synchronism will be lost unless the fault is cleared in time.

The circuit breakers at the two ends of the faulted line open at time t_c (corresponding to angle δ_c), the clearing time, disconnecting the faulted line.

The power flow is now restored via the healthy line (through higher line reactance X_2 in place of $X_1 // X_2$), with power angle curve

$$P_{eII} = \frac{|E'V|}{X'_d + X_1 X_2} \sin \delta = P_{\max II} \sin \delta$$

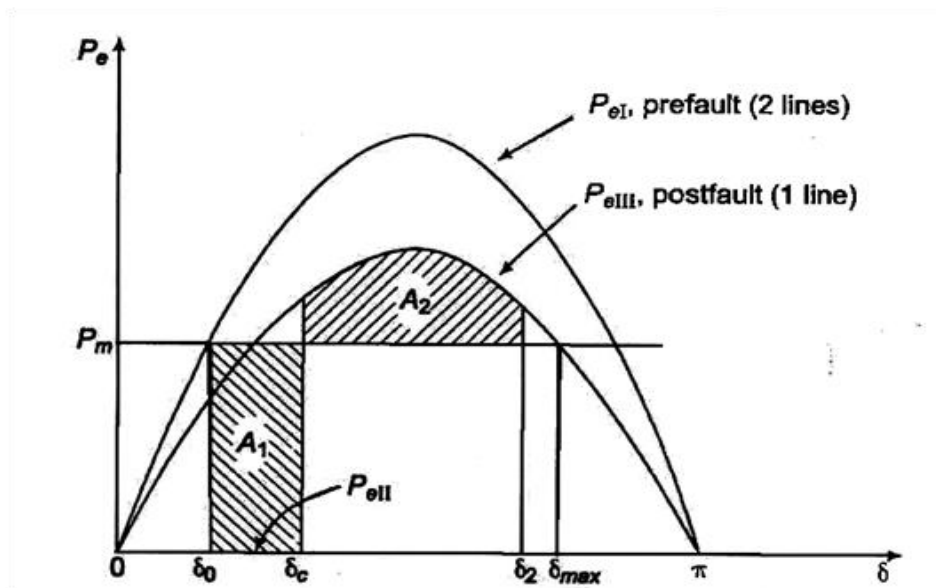

Fig. 4.13 Equal area criteria applied to the system, I system is normal, II fault applied, III faulted line isolated.

Obviously, $P_{maxII} < P_{maxI}$. The rotor now starts to decelerate as shown in Fig. 4.13. The system will be stable if a decelerating area A_2 can be found equal to accelerating area A_1 before δ reaches the maximum allowable value δ_{max} . As area A_1 depends upon clearing time t_c (corresponding to clearing angle δ_c), clearing time must be less than a certain value (critical clearing time) for the system to be stable. It is to be observed that the equal area criterion helps to determine critical clearing angle and not critical clearing time. Critical clearing time can be obtained by numerical solution of the swing equation

It also easily follows that larger initial loading (P_m) increases A_1 for a given clearing angle (and time) and therefore quicker fault clearing would be needed to maintain stable operation. The power angle curve during fault is therefore given by

$$P_{eII} = \frac{|E'| |V|}{X_{II}} \sin \delta = P_{maxII} \sin \delta$$

P_{eI} , P_{eIII} and P_{eII} as obtained above are all plotted in Fig.4.14. Accelerating area A_1 corresponding to a given clearing angle δ is less in this case then in case a giving a better chance for stable operation. Stable system operation is shown in Fig. 4.14, wherein it is possible to find an area A_2 equal to A_1 for $\delta_2 < \delta_{max}$. As the clearing angle δ_c is increased, area A_1 increases and to find $A_2 = A_1$, δ_2 increases till it has a value δ_{max} , the maximum allowable for stability This case of critical clearing angle is shown in Fig. 4.15

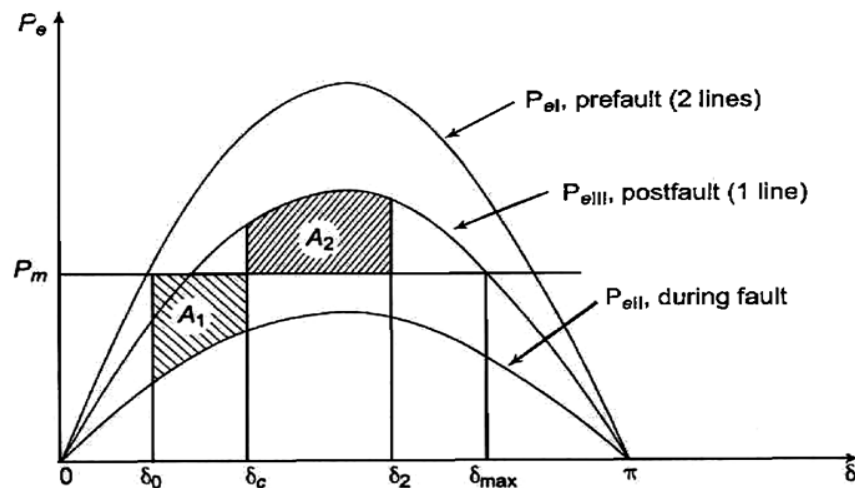

Fig. 4.14 Fault on middle of one line of the system with $\delta_c < \delta_{cr}$

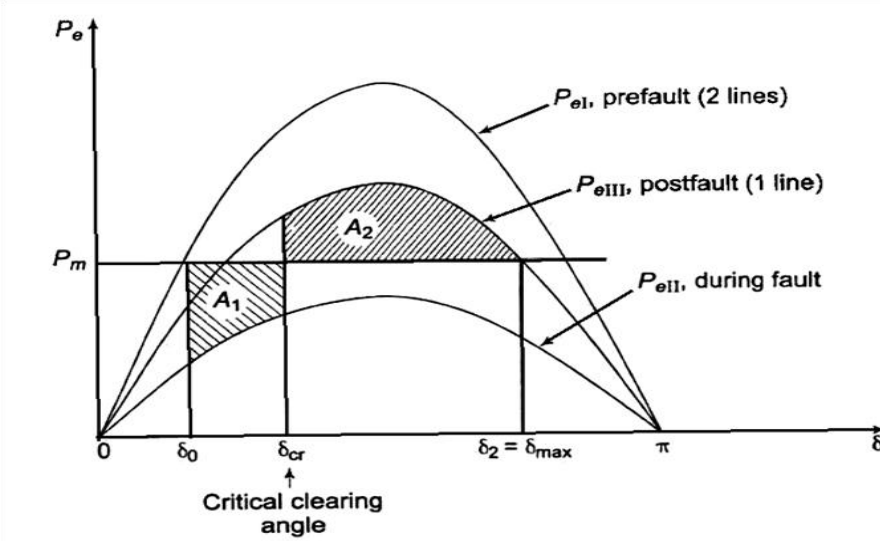

Fig.4.15 Fault on middle of one line of the system of, case of critical clearing angle

Applying equal area criterion to the case of critical clearing angle of Fig. 4.15 we can write

$$\int_{\delta_0}^{\delta_{cr}} (P_m - P_{\max II} \sin \delta) d\delta = \int_{\delta_{cr}}^{\delta_{\max}} (P_{\max III} \sin \delta - P_m) d\delta$$

where

$$\delta_{\max} = \pi - \sin^{-1} \left(\frac{P_m}{P_{\max III}} \right) \quad (4.63)$$

Integrating, we get

$$(P_m \delta + P_{\max II} \cos \delta) \Big|_{\delta_0}^{\delta_{cr}} + (P_{\max III} \cos \delta - P_m \delta) \Big|_{\delta_{cr}}^{\delta_{\max}} = 0$$

OR

$$P_m (\delta_{cr} - \delta_0) + P_{\max II} (\cos \delta_{cr} + \cos \delta_0) + P_m (\delta_{\max} - \delta_{cr}) + P_{\max III} (\cos \delta_{\max} + \cos \delta_{cr}) = 0$$

OR

$$\cos \delta_{cr} = \frac{P_m (\delta_{\max} - \delta_0) - P_{\max II} \cos \delta_0 + P_{\max III} \cos \delta_{\max}}{P_{\max III} - P_{\max II}} \quad (4.64)$$

Critical clearing angle can be calculated from Eq. (4.64) above. The angles in the equation are in radians. The equation modifies as below if the angle are in degrees.

$$\cos \delta_{cr} = \frac{\frac{\pi}{180} P_m (\delta_{\max} - \delta_0) - P_{\max II} \cos \delta_0 + P_{\max III} \cos \delta_{\max}}{P_{\max III} - P_{\max II}}$$

If the circuit breakers of line 2 are reclosed successfully (i.e., the fault was a transient one and therefore vanished on clearing the faulty line), the power transfer once again becomes

$$P_{eIV} = P_{eI} = P_{\max I} \sin \delta$$

Since reclosure restores power transfer, the chances of stable operation improve. A case of stable operation is indicated by Fig. 4.16. For critical clearing angle

$$\delta_1 = \delta_{\max} = \pi - \sin^{-1} \left(\frac{P_m}{P_{\max I}} \right)$$

$$\int_{\delta_0}^{\delta_{cr}} (P_m - P_{\max II} \sin \delta) d\delta = \int_{\delta_{cr}}^{\delta_{rc}} (P_{\max III} \sin \delta - P_m) d\delta + \int_{\delta_{rc}}^{\delta_{\max}} (P_{\max I} \sin \delta - P_m) d\delta$$

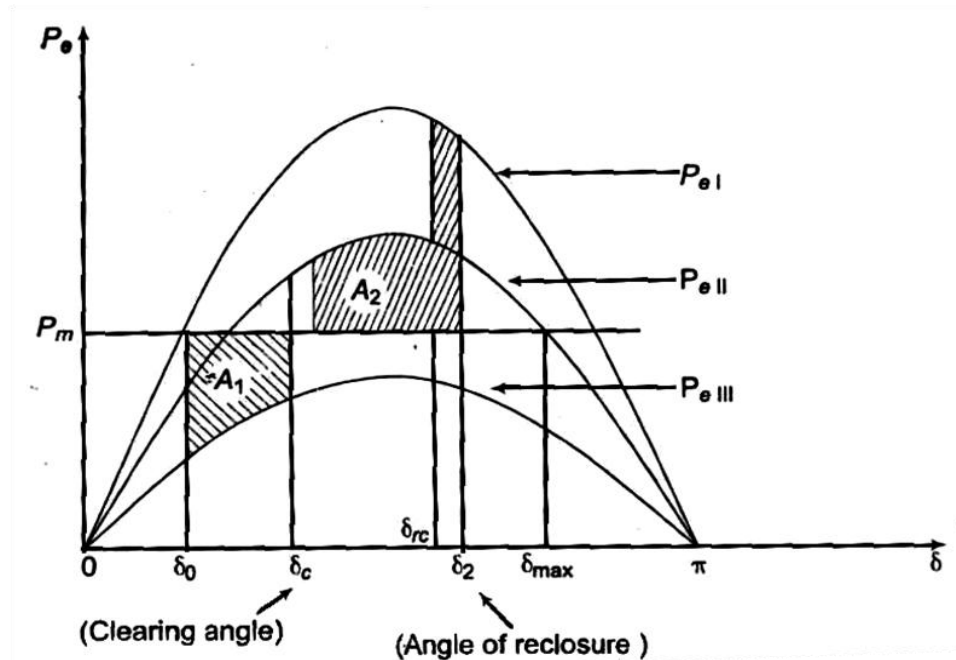

Fig. 4.16 fault in middle of a line of the system

Point To Point Method of Improvement of Transient Stability

In most practical systems, after machine lumping has been done, there are still more than two machines to be considered from the point of view of system stability. Therefore, there is no choice but to solve the swing equation of each machine by a numerical technique on the digital computer. Even in the case of a single machine tied to infinite bus bar, the critical clearing time cannot be obtained from equal area criterion and we have to make this calculation numerically through swing equation. There are several sophisticated methods now available for the solution of the swing equation including the powerful Runge-Kutta method. Here we shall treat the point-by-point method of solution which is a conventional, approximate method like all numerical methods but a well tried and proven one. We shall illustrate the point-by-point method for one machine tied to infinite bus bar. The procedure is, however, general and can be applied to every machine of a multi-machine system. Consider the swing equation

$$\frac{d^2 \delta}{dt^2} = \frac{1}{M} (P_m - P_{\max} \sin \delta) = \frac{P_a}{M}$$

$$M = \frac{GH}{\pi}$$

Or in p.u $M = \frac{H}{\pi f}$

The solution $\delta(t)$ is obtained at discrete intervals of time with interval spread of Δt uniform throughout. Accelerating power and change in speed which are continuous functions of time are discretized as below:

1. The accelerating power P_a computed at the beginning of an interval is assumed to remain constant from the middle of the preceding interval to the middle of the interval being considered as shown in Fig. 4.17.
2. The angular rotor velocity $\omega = d\delta/dt$ (over and above synchronous velocity ω_s) is assumed constant throughout any interval, at the value computed for the middle of the interval as shown in fig . 4.17

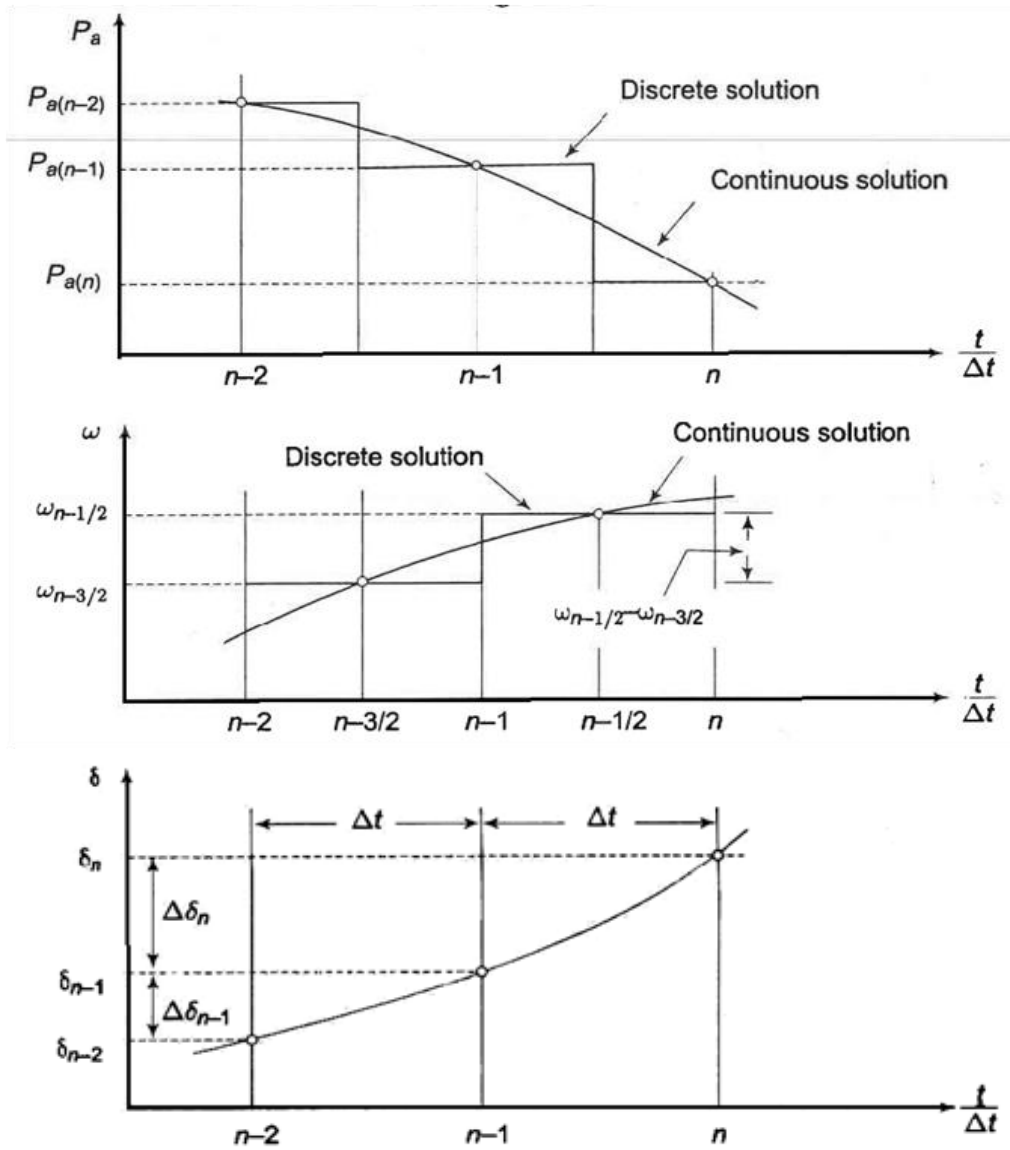

Fig. 4.17 Point-by-point solution of swing equation

In Fig.4.17, the numbering on $t/\Delta t$ axis pertains to the end of intervals. At the end of the $(n-1)$ th interval, the acceleration power is

$$P_{a(n-1)} = P_m - P_{\max} \sin \delta_{n-1} \quad (4.65)$$

Where δ_{n-1} has been previously calculated. The change in velocity ($\omega = d\delta/dt$), caused by the $P_{a(n-1)}$, assumed constant over Δt from $(n-3/2)$ to $(n-1/2)$ is

$$\omega_{n-1/2} - \omega_{n-3/2} = (\Delta t / M) P_{a(n-1)} \quad (4.66)$$

The change in δ during the (n-1)th interval is

$$\Delta\delta_n = \delta_{n-1} - \delta_{n-2} = \Delta t \omega_{n-3/2} \quad (4.67)$$

And during the nth interval

$$\Delta\delta_n = \delta_n - \delta_{n-1} = \Delta t \omega_{n-1/2} \quad (4.68)$$

Subtracting Eq. (4.67) from Eq. (4.68) and using Eq. (4.65), we get

$$\Delta\delta_n = \Delta\delta_{n-1} + \frac{(\Delta t)^2}{M} P_{a(n-1)} \quad (4.69)$$

Using this, we can write

$$\delta_n = \delta_{n-1} + \Delta\delta_n \quad (4.70)$$

The process of computation is now repeated to obtain $P_{a(n)}, \Delta\delta_{n+1}$ and δ_{n+1} . The time solution in discrete form is thus carried out over the desired length of time, normally 0.5 s. Continuous form of solution is obtained by drawing a smooth curve through discrete values as shown in Fig. 4.17. Greater accuracy of solution can be achieved by reducing the time duration of intervals.

The occurrence or removal of a fault or initiation of any switching event causes a discontinuity in accelerating power P_a . If such a discontinuity occurs at the beginning of an interval, then the average of the values of P_a before and after the discontinuity must be used. Thus, in computing the increment of angle occurring during the first interval after a fault is applied at $t = 0$, Eq. (4.69) becomes

$$\Delta\delta_1 = \frac{(\Delta t)^2}{M} + \frac{P_{a0+}}{2}$$

Where (P_{a0+}) accelerating power after fault. Immediately before the fault the system is in steady state, so that $P_{a0-} = 0$ and δ_0 is a known value. If the fault is cleared at the beginning of the n th interval, in calculation for this interval one should use for $P_{a(n-1)}$ the value $\frac{1}{2}[P_{a(n-1)-} + P_{a(n-1)+}]$, where $P_{a(n-1)-}$ is the accelerating power immediately before clearing and $P_{a(n-1)+}$ is that immediately after clearing the fault. If the discontinuity occurs at the middle of an interval, no special procedure is needed. The increment of angle during such an interval is calculated, as usual, from the value of P_a at the beginning of the interval.

Voltage Stability

Power transmission capacity has traditionally been limited by either rotor angle (synchronous) stability or by thermal loading capabilities. The blackout problem has been linked with transient stability. Luckily this problem is now not that serious because of fast short circuit clearing, power excitation systems, and other special stability controls. Electrical companies are now required to squeeze the maximum possible power through existing networks owing to various constraints in the construction of generation and transmission facilities.

Voltage (load) stability, however, is now a main issue in planning and operating electric power systems and is a factor leading to limit power transfers. Voltage stability is concerned with the ability of a power system to maintain acceptable voltages at all buses in the system under normal conditions and after being subjected to a disturbance. A power system is said to have entered a state of voltage instability when a disturbance results in a progressive and uncontrollable decline in voltage

Inadequate reactive power support from generators and transmission lines leads to voltage instability or voltage collapses, which have resulted in several major system failures in the world. They are:

- (i) South Florida, USA, system disturbance of 17 May 1985,
- (ii) French system disturbances of December 19, 1978 and January 12, 1987, (longer term).
- (iii) Swedish system disturbance of December 27, 1983 (longer term, 55 sec).
- (iv) Japanese(Tokyo) system disturbance of July 23, 1987 (longer term, 20 min).
- (v) NREB grid disturbance in India in 1984 and 1987.
- (vi) Belgium, Aug 4, 1982 (longer term, 4.5 min).
- (vii) Baltimore, Washington DC, USA, 5th July 1990 (longer term, insecure for hours).

Hence, a full understanding of voltage stability phenomena and designing mitigation schemes to prevent voltage instability is of great value to utilities. Consequently over the last ten years, utility engineers, consultants and researchers have thoroughly studied voltage stability.

Voltage stability covers a wide range of phenomena. Because of this, voltage stability means different things to different engineers. Voltage instability and voltage collapse are used somewhat interchangeably by many researchers. Voltage instability or collapse is a faster dynamic-process. As opposed to angle

Voltage instability or collapse is a faster dynamic-process. As opposed to angle stability, the dynamics mainly involves the loads and the means for voltage control.

Effective Counter Measures to Prevent or Contain Voltage Instability

- (i) Generator terminal voltage should be raised.
- (ii) Generator transformer tap value may be increased.
- (iii) Q-injection should be carried out at an appropriate location.
- (iv) Load-end OLTC (on-load tap changer) should be suitably used.
- (v) For under voltage conditions, strategic load shedding should be resorted to.

System reinforcement may be carried out by installing new transmission lines between generation and load centers. Series and shunt compensation may be carried out and SVCs (static VAR compensation) may be installed. Practical aspects of Q-flow problems leading to voltage collapse in EHV lines:

- (i) For long lines with uncontrolled buses, receiving end or load voltages increase for light load conditions and decrease for heavy load conditions.
- (ii) For radial transmission lines, if any loss of a line takes place, reactance goes up, I^2X loss increases resulting in increase in voltage drop. This should be suitably compensated by local Q injection. Of course this involves cost. If there is a shortage of local Q sources, then import of Q through long line may have to be resorted to. However, this is not desirable

Only the operating points above the critical points represent satisfactory operating conditions. At the 'knee' of the V-P curve, the voltage drops rapidly with an increase in load demands. Power-flow solution fails to converge beyond this limit indicating instability. Operation at or near the stability limit is impractical and a satisfactory operating condition is ensured by permitting sufficient "power margin".

Voltage Collapse

Voltage collapse is the process by which the sequence of events accompanying voltage instability leads to unacceptable voltage profile in a significant part of the power system. It may be manifested in several different ways. Voltage collapse may be characterized as follows:

- (i) The initiating event may be due to variety of reasons: Small gradual system change such as natural increase in system load, or large sudden disturbance such as loss of a generating unit or a heavily loaded line.

(ii) The crux of the problem is the inability of the system to meet its reactive demands. When transport of reactive power from neighboring areas is difficult, any change that requires additional reactive power support may eventually lead to voltage collapse.

(iii) The voltage collapse generally manifests itself as a slow decay of voltage. It is the result of an accumulative process involving the actions and interactions of many devices, controls, and protective systems. The time frame of collapse in such cases would be of the order of several minutes. Voltage collapse is strongly influenced by system conditions and characteristics.

(iv) Reactive compensation can be made most effective by the judicious choice of a mixture of shunt capacitors, static VAR compensator and possibly synchronous condensers.

Methods of Improving Voltage Stability

- i. Voltage stability can be improved by adopting the following means:
- ii. Enhancing the localised reactive power support (SVC) is more effective and C-banks are more economical. FACTS devices or synchronous condenser may also be used,
- iii. Compensating the line length reduces net reactance and power flow increases.
- iv. Additional transmission line may be erected. It also improves reliability.
- v. Enhancing excitation of generator, system voltage improves and Q is supplied to the system.
- vi. HVDC tie may be used between regional grids.
- vii. By resorting to strategic load shedding, voltage goes up as the reactive burden is reduced.