

## MODULE III

### Brakes, Clutches and Flywheel,

#### Brakes

- *A brake is a device by means of which artificial resistance is applied on to a moving machine member in order to retard or stop the motion of the member or machine*

#### Types of Brakes

- *Different types of brakes are used in different applications*
- *Based on the working principle used brakes can be classified as mechanical brakes, hydraulic brakes, electrical (eddy current) magnetic and electro-magnetic types.*

#### Mechanical Brakes

- Mechanical brakes are invariably based on the frictional resistance principles•  
In mechanical brakes artificial resistances created using frictional contact between the moving member and a stationary member, to retard or stop the motion of the moving member.

#### Basic mechanism of braking

The illustration below explains the working of mechanical brakes. An element  $dA$  of the stationary member is shown with the braked body moving past at velocity  $v$ . When the brake is actuated contact is established between the stationary and moving member and a normal pressure is developed in the contact region. The elemental normal force  $dN$  is equal to the product of contact pressure  $p$  and area of contact  $dA$ . As one member is stationary and the other is in relative motion, a frictional force  $dF$  is developed between the members. The

magnitude of the frictional force is equal to the co-efficient of friction times the normal force  $dN$

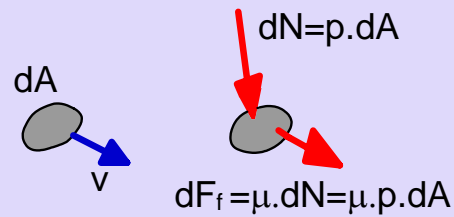

Figure 3.1.1

The moment of the frictional force relative to the point of motion contributes to the retardation of motion and braking. The basic mechanism of braking is illustrated above.

### Design and Analysis

To design, select or analyze the performance of these devices knowledge on the following are required.

- *The braking torque*
- *The actuating force needed*
- *The energy loss and temperature rise*

At this beginning stage attention will be focused mainly on some preliminary analysis related to these aspects, namely torque, actuating force, energy absorbed and temperature rise. Torque induced is related to the actuating force, the geometry of the member and other contact conditions. Most mechanical brakes that work on the frictional contact basis are classified based on the geometry.

There are two major classes of brakes, namely drum brakes and disc brakes. Design and analysis of drum brakes will be considered in detail in following

sections, the discussion that follow on disc or plate clutches will form the basis for design of disc type of brakes.

Drum brakes basically consists of a rotating body called drum whose motion is braked together with a shoe mounted on a lever which can swing freely about a fixed hinge H. A lining is attached to the shoe and contacts the braked body. The actuation force  $P$  applied to the shoe gives rise to a normal contact pressure distributed over the contact area between the lining and the braked body. A corresponding friction force is developed between the stationary shoe and the rotating body which manifest as retarding torque about the axis of the braked body.

### Brakes Classification

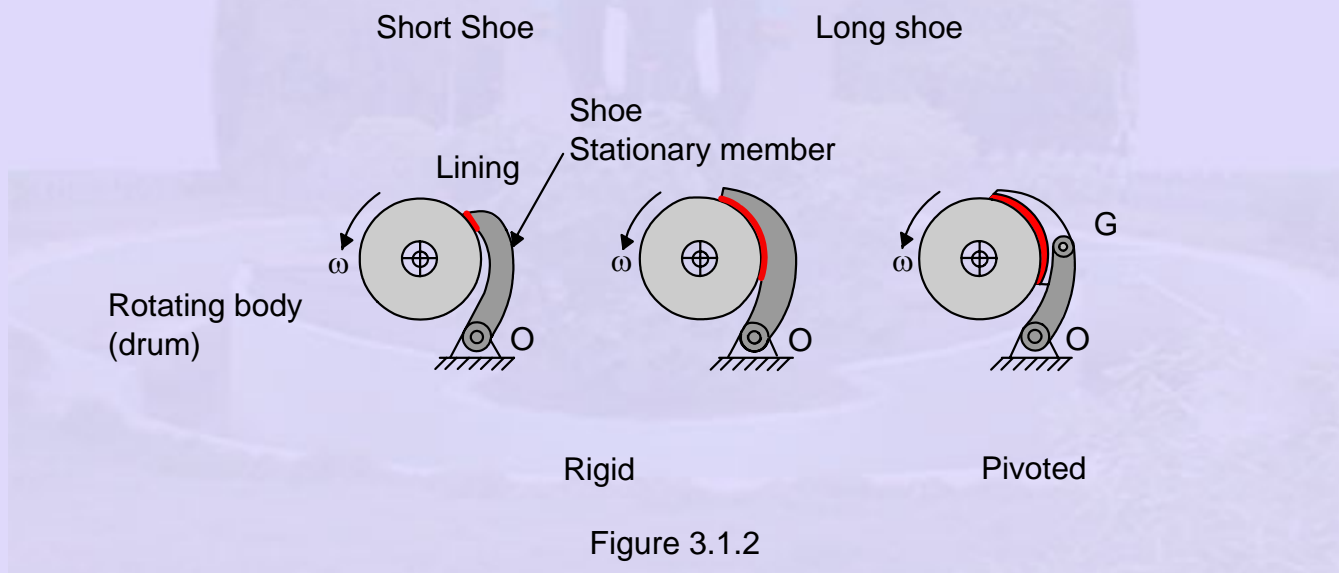

Figure 3.1.2

Various geometric configurations of drum brakes are illustrated above.

Drum Brakes are classified based on the shoe geometry. Shoes are classified as being either short or long. A short shoe is one whose lining dimension in the direction of motion is so small that contact pressure variation is negligible, i.e. the pressure is uniform everywhere.

When the area of contact becomes larger, the contact may no longer be with a uniform pressure, in which case the shoe is termed as long shoe. The shoes are either rigid or pivoted, pivoted shoes are also some times known as hinged shoes. The shoe is termed rigid because the shoes with attached linings are rigidly connected to the pivoted posts. In a hinged shoe brake - the shoes are not rigidly fixed but hinged or pivoted to the posts. The hinged shoe is connected to the actuating post by the hinge, G, which introduces another degree of freedom

### **Preliminary Analysis**

The figure shows a brake shoe mounted on a lever, hinged at O, having an actuating force  $F_a$ , applied at the end of the lever. On the application of an actuating force, a normal force  $F_n$  is created when the shoe contacts the rotating drum. And a frictional force  $F_f$  of magnitude  $f.F_n$ ,  $f$  being the coefficient of friction, develops between the shoe and the drum. Moment of this frictional force about the drum center constitutes the braking torque.

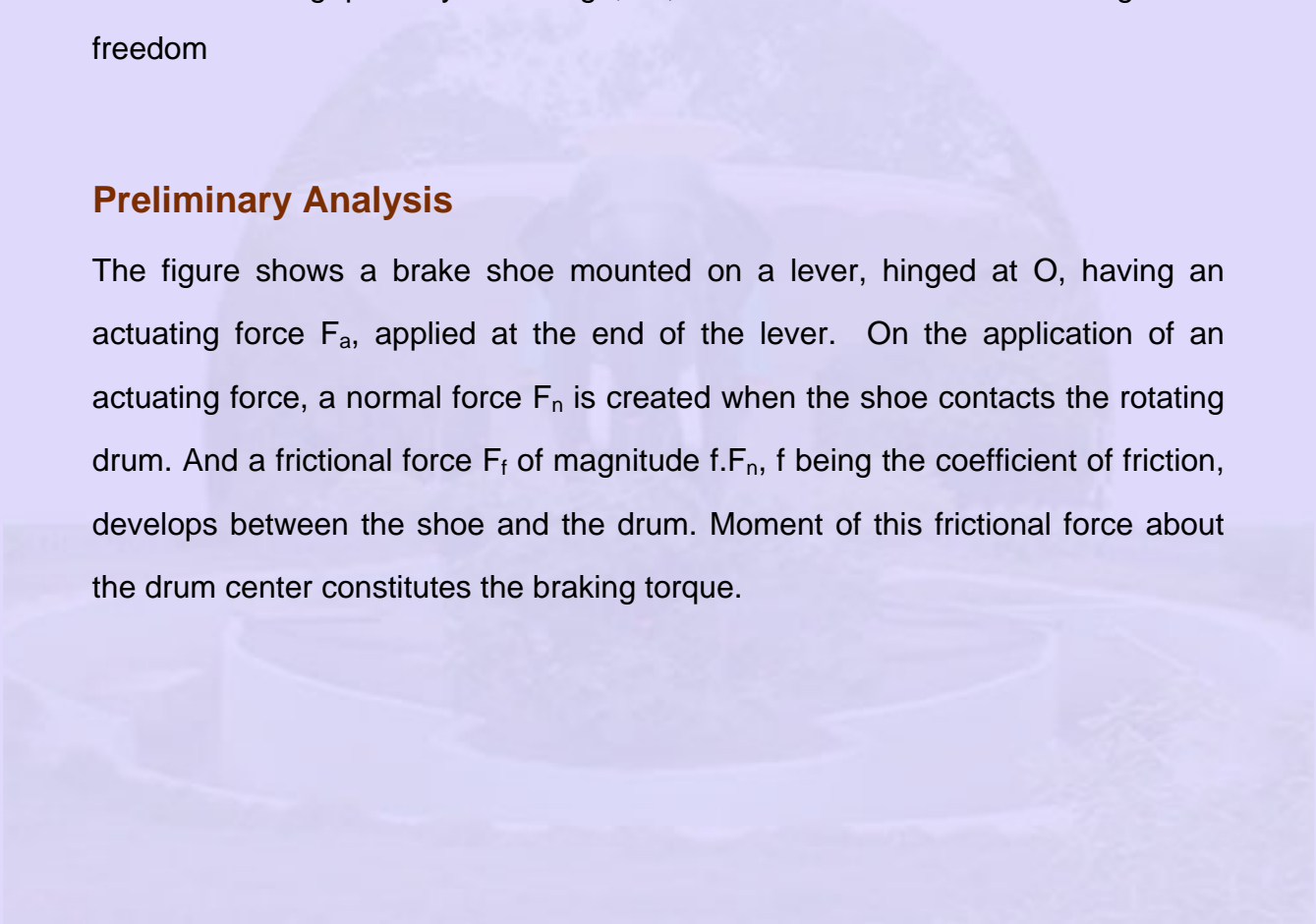

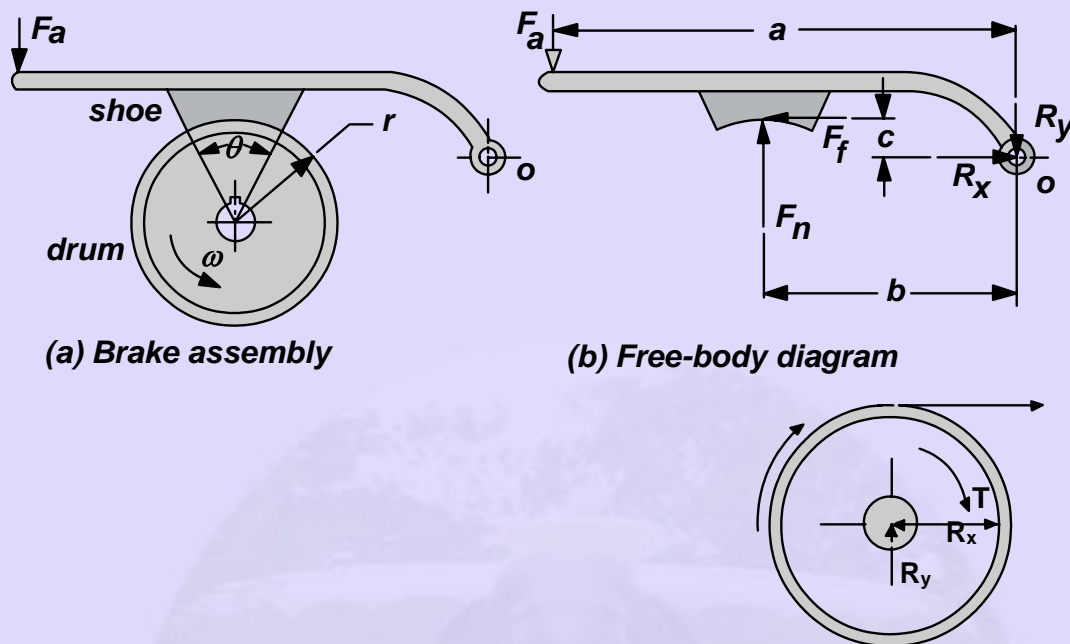

Figure 3.1.3

### Short Shoe Analysis

For a short shoe we assume that the pressure is uniformly distributed over the contact area. Consequently the equivalent normal force  $F_n = p \cdot A$ , where  $p$  is the contact pressure and  $A$  is the surface area of the shoe. Consequently the friction force  $F_f = f \cdot F_n$  where  $f$  is the co-efficient of friction between the shoe lining material and the drum material.

The torque on the brake drum is then,

$$T = f F_n \cdot r = f \cdot p \cdot A \cdot r$$

A quasi static analysis is used to determine the other parameters of braking.

Applying the equilibrium condition by taking moment about the pivot 'O' we can write

$$\sum M_O = F_a \cdot a - F_n \cdot b + f \cdot F_n \cdot c = 0$$

Substituting for  $F_n$  and solving for the actuating force, we get,

$$F_a = F_n(b+fc)/a$$

The reaction forces on the hinge pin (pivot) are found from a summation of forces,

i.e.

$$F_x = 0, R_x = fp_a A$$

$$F_y = 0, R_y = p_a A - F_a$$

### Self-energizing

The principle of self energizing and leading and trailing shoes

With the shown direction of the drum rotation (CCW), the moment of the frictional force  $f \cdot F_n \cdot c$  adds to the moment of the actuating force,  $F_a$

As a consequence, the required actuation force needed to create a known contact pressure  $p$  is much smaller than that if this effect is not present. This phenomenon of frictional force aiding the brake actuation is referred to as *self-energization*.

### Leading and trailing shoe

- For a given direction of rotation the shoe in which self energization is present is known as the leading shoe
- When the direction of rotation is changed, the moment of frictional force now will be opposing the actuation force and hence greater magnitude of force is needed to create the same contact pressure. The shoe on which this is prevailing is known as a trailing shoe

## Self Locking

At certain critical value of  $f.c$  the term  $(b-fc)$  becomes zero. i.e no actuation force need to be applied for braking. This is the condition for *self-locking*. Self-locking will not occur unless it is specifically desired.

## Short and Long Shoe Analysis

- Foregoing analysis is based on a constant contact pressure  $p$ .
- In reality constant or uniform constant pressure may not prevail at all points of contact on the shoe.
- In such case the following general procedure of analysis can be adopted

## General Procedure of Analysis

- Estimate or determine the distribution of pressure on the frictional surfaces
- Find the relation between the maximum pressure and the pressure at any point
- For the given geometry, apply the condition of static equilibrium to find the actuating force, torque and reactions on support pins etc.

